



# Sun Fire™ V210 and V240 Server Netra™ 240 Server CPU Upgrade Guide

---

Sun Microsystems, Inc.  
4150 Network Circle  
Santa Clara, CA 95054 U.S.A.  
650-960-1300

Part No. 817-4146-11  
January 2004, Revision A

Send comments about this document to: [docfeedback@sun.com](mailto:docfeedback@sun.com)

Copyright 2004 Sun Microsystems, Inc., 4150 Network Circle, Santa Clara, California 95054, U.S.A. All rights reserved.

Sun Microsystems, Inc. has intellectual property rights relating to technology embodied in the product that is described in this document. In particular, and without limitation, these intellectual property rights may include one or more of the U.S. patents listed at <http://www.sun.com/patents> and one or more additional patents or pending patent applications in the U.S. and in other countries.

This document and the product to which it pertains are distributed under licenses restricting their use, copying, distribution, and decompilation. No part of the product or of this document may be reproduced in any form by any means without prior written authorization of Sun and its licensors, if any.

Third-party software, including font technology, is copyrighted and licensed from Sun suppliers.

Parts of the product may be derived from Berkeley BSD systems, licensed from the University of California. UNIX is a registered trademark in the U.S. and in other countries, exclusively licensed through X/Open Company, Ltd.

Sun, Sun Microsystems, the Sun logo, AnswerBook2, docs.sun.com, Sun Fire, Netra and Solaris are trademarks or registered trademarks of Sun Microsystems, Inc. in the U.S. and in other countries.

All SPARC trademarks are used under license and are trademarks or registered trademarks of SPARC International, Inc. in the U.S. and in other countries. Products bearing SPARC trademarks are based upon an architecture developed by Sun Microsystems, Inc. The Energy Star logo is a registered trademark of EPA.

The OPEN LOOK and Sun™ Graphical User Interface was developed by Sun Microsystems, Inc. for its users and licensees. Sun acknowledges the pioneering efforts of Xerox in researching and developing the concept of visual or graphical user interfaces for the computer industry. Sun holds a non-exclusive license from Xerox to the Xerox Graphical User Interface, which license also covers Sun's licensees who implement OPEN LOOK GUIs and otherwise comply with Sun's written license agreements.

Use, duplication, or disclosure by the U.S. Government is subject to restrictions set forth in the Sun Microsystems, Inc. license agreements and as provided in DFARS 227.7202-1(a) and 227.7202-3(a) (1995), DFARS 252.227-7013(c)(1)(ii) (Oct. 1998), FAR 12.212(a) (1995), FAR 52.227-19, or FAR 52.227-14 (ALT III), as applicable.

DOCUMENTATION IS PROVIDED "AS IS" AND ALL EXPRESS OR IMPLIED CONDITIONS, REPRESENTATIONS AND WARRANTIES, INCLUDING ANY IMPLIED WARRANTY OF MERCHANTABILITY, FITNESS FOR A PARTICULAR PURPOSE OR NON-INFRINGEMENT, ARE DISCLAIMED, EXCEPT TO THE EXTENT THAT SUCH DISCLAIMERS ARE HELD TO BE LEGALLY INVALID.

---

Copyright 2004 Sun Microsystems, Inc., 4150 Network Circle, Santa Clara, California 95054, Etats-Unis. Tous droits réservés.

Sun Microsystems, Inc. a les droits de propriété intellectuels relatants à la technologie incorporée dans le produit qui est décrit dans ce document. En particulier, et sans la limitation, ces droits de propriété intellectuels peuvent inclure un ou plus des brevets américains énumérés à <http://www.sun.com/patents> et un ou les brevets plus supplémentaires ou les applications de brevet en attente dans les Etats-Unis et dans les autres pays.

Ce produit ou document est protégé par un copyright et distribué avec des licences qui en restreignent l'utilisation, la copie, la distribution, et la décompilation. Aucune partie de ce produit ou document ne peut être reproduite sous aucune forme, par quelque moyen que ce soit, sans l'autorisation préalable et écrite de Sun et de ses bailleurs de licence, s'il y en a.

Le logiciel détenu par des tiers, et qui comprend la technologie relative aux polices de caractères, est protégé par un copyright et licencié par des fournisseurs de Sun.

Des parties de ce produit pourront être dérivées des systèmes Berkeley BSD licenciés par l'Université de Californie. UNIX est une marque déposée aux Etats-Unis et dans d'autres pays et licenciée exclusivement par X/Open Company, Ltd.

Sun, Sun Microsystems, le logo Sun, AnswerBook2, docs.sun.com, Sun Fire, Netra et Solaris sont des marques de fabrique ou des marques déposées de Sun Microsystems, Inc. aux Etats-Unis et dans d'autres pays.

Toutes les marques SPARC sont utilisées sous licence et sont des marques de fabrique ou des marques déposées de SPARC International, Inc. aux Etats-Unis et dans d'autres pays. Les produits portant les marques SPARC sont basés sur une architecture développée par Sun Microsystems, Inc.

L'interface d'utilisation graphique OPEN LOOK et Sun™ a été développée par Sun Microsystems, Inc. pour ses utilisateurs et licenciés. Sun reconnaît les efforts de pionniers de Xerox pour la recherche et le développement du concept des interfaces d'utilisation visuelle ou graphique pour l'industrie de l'informatique. Sun détient une licence non exclusive de Xerox sur l'interface d'utilisation graphique Xerox, cette licence couvrant également les licenciés de Sun qui mettent en place l'interface d'utilisation graphique OPEN LOOK et qui en outre se conforment aux licences écrites de Sun.

LA DOCUMENTATION EST FOURNIE "EN L'ÉTAT" ET TOUTES AUTRES CONDITIONS, DECLARATIONS ET GARANTIES EXPRESSES OU TACITES SONT FORMELLEMENT EXCLUES, DANS LA MESURE AUTORISÉE PAR LA LOI APPLICABLE, Y COMPRIS NOTAMMENT TOUTE GARANTIE IMPLICITE RELATIVE A LA QUALITE MARCHANDE, A L'APTITUDE A UNE UTILISATION PARTICULIERE OU A L'ABSENCE DE CONTREFAÇON.



# Contents

---

Typographic Conventions xii

Shell Prompts xiii

## **1. Introduction 1**

Supported Upgrade Paths 2

## **2. Sun Fire V210 and V240 Servers 3**

Tools Required 3

Inventory Check 4

Server Precheck 4

Preparing the Server 6

Antistatic Precautions 6

▼ To Shut Down the Server 7

▼ To Open the Lid 7

CPU Upgrades 9

▼ To Remove a CPU 9

▼ To Install a CPU 9

▼ To Install the Heat Sink 10

Jumper Settings 11

Memory 12

|   |           |
|---|-----------|
| Memory Configuration Rules  | 13        |
| Part Number Labels  | 13        |
| ▼ To Apply the System Board Upgrade Notification Label            | 14        |
| Closing the Server Lid  | 15        |
| Verify Installation   | 15        |
| Updating the FRU ID   | 16        |
| ▼ To Run the Update Utility                                       | 16        |
| <b>3. Netra 240 Server</b>  | <b>19</b> |
| Tools Required  | 19        |
| Inventory Check   | 20        |
| Server Precheck   | 20        |
| Preparing the Server  | 22        |
| Antistatic Precautions  | 23        |
| ▼ To Shut Down the Server   | 23        |
| ▼ To Access the Internal Components                               | 25        |
| CPU Upgrades  | 28        |
| ▼ To Install the CPU  | 28        |
| ▼ To Install the Heat Sink  | 28        |
| Jumper Settings   | 29        |
| Part Number Labels  | 30        |
| Reassembling and Reinstalling the Server                          | 30        |
| Verify Installation   | 31        |
| Updating the FRU ID   | 32        |
| ▼ To Run the Update Utility                                       | 32        |
| <b>A. For Host Servers Without a Built-In Optical Media Drive</b> | <b>35</b> |
| ▼ To Mount the CD-ROM on a Remote Host                            | 35        |
| <b>B. Upgrade Problems</b>  | <b>37</b> |

**C. Upgrade Checklist 39**

**D. Upgrade Utility Download 41**

▼ To download the utility software 41



# Figures

---

- FIGURE 2-1 Antistatic wrist strap attaching point 7
- FIGURE 2-2 Lifting the lid 8
- FIGURE 2-3 CPU alignment 10
- FIGURE 2-4 Location of JP4 12
- FIGURE 2-5 Placing the system board label 14
- FIGURE 2-6 Applying the system label to the bezel 16
- FIGURE 3-1 Finger holds on bezel 23
- FIGURE 3-2 Rotary switch positions 24
- FIGURE 3-3 Removing the server lid 25
- FIGURE 3-4 Lowering the rotating service module 26
- FIGURE 3-5 Avoiding the Netra 240 server tip hazard 27
- FIGURE 3-6 Grounding point in the server 27
- FIGURE 3-7 Removing the fans from the heat sink assemblies 29



# Tables

---

|           |  |    |
|-----------|--|----|
| TABLE 2-1 | JP4: Required Jumper Setting Per Processor Speed | 11 |
| TABLE 2-2 | Upgrade identification labels                    | 13 |
| TABLE 3-1 | Upgrade identification labels                    | 30 |



# Preface

---

---

# Using UNIX Commands

This document does not contain information on basic UNIX® commands and procedures such as shutting down the system, booting the system, and configuring devices.

See one or more of the following for this information:

- *Solaris Handbook for Sun Peripherals*
- Other software documentation that you received with your system

---

# Typographic Conventions

| Typeface         | Meaning  | Examples   |
|------------------|--|--|
| AaBbCc123        | The names of commands, files, and directories; on-screen computer output   | Edit your <code>.login</code> file.<br>Use <code>ls -a</code> to list all files.<br>% You have mail.   |
| <b>AaBbCc123</b> | What you type, when contrasted with on-screen computer output  | % <b>su</b><br>Password:   |
| <i>AaBbCc123</i> | Book titles, new words or terms, words to be emphasized. Replace command-line variables with real names or values. | Read Chapter 6 in the <i>User's Guide</i> .<br>These are called <i>class</i> options.<br>You <i>must</i> be superuser to do this.<br>To delete a file, type <code>rm filename</code> . |

---

# Shell Prompts

| Shell                                 | Prompt               |
|---------------------------------------|----------------------|
| C shell                               | <i>machine-name%</i> |
| C shell superuser                     | <i>machine-name#</i> |
| Bourne shell and Korn shell           | \$                   |
| Bourne shell and Korn shell superuser | #                    |
| ALOM shell                            | sc>                  |
| OpenBoot PROM shell                   | ok                   |

---

# Accessing Sun Documentation Online

You can view, print, or purchase a broad selection of Sun documentation, including localized versions, at:

<http://www.sun.com/documentation/>

---

# Sun Welcomes Your Comments

Sun is interested in improving its documentation and welcomes your comments and suggestions. You can email your comments to Sun at:

[docfeedback@sun.com](mailto:docfeedback@sun.com)

Please include the part number of the document in the subject line of your email.



# Introduction

---

This document describes the procedure for upgrading the CPU or CPUs in the Sun Fire V210 and V240 servers and Netra 240 server.



---

**Caution** – The procedures described in this document are to be performed by service personnel only.

---

To arrange for installation by Sun Services, refer to [www.sun.com/service/contacting](http://www.sun.com/service/contacting).

---

**Note** – If the host server does not have an optical media drive, see Appendix A.

---

---

**Note** – If you encounter any problems with the server at any stage of the upgrade procedure, see Appendix B.

---

---

**Note** – Complete the checklist in Appendix C as you work through these procedures.

---

---

# Supported Upgrade Paths

The supported upgrade paths are:

- Sun Fire V210 and V240 servers: single 1GHz to dual 1GHz
- Sun Fire V240 server: single or dual 1GHz to single or dual 1.28GHz
- Sun Fire V240 server: single 1.28GHz to dual 1.28GHz
- Netra 240 server: single 1.28GHz to dual 1.28GHz

---

**Note** – Mixed CPU speeds are not supported.

---

## Sun Fire V210 and V240 Servers

---

This chapter describes how to install the hardware into the Sun Fire V210 and V240 servers.

It contains the following sections:

- “Tools Required” on page 3
- “Inventory Check” on page 4
- “Server Precheck” on page 4
- “Preparing the Server” on page 6
- “CPU Upgrades” on page 9
- “Jumper Settings” on page 11
- “Part Number Labels” on page 13
- “Closing the Server Lid” on page 15
- “Updating the FRU ID” on page 16

---

### Tools Required

- Phillips No.2 screwdriver

---

# Inventory Check

**1. Check that all of the following components are present in the upgrade kit:**

- CPU
- Heat sink assembly
- Jumper (2mm)
- Documentation
- CD-ROM
- Anti-static wrist strap
- Part number label sheet

**2. Ensure that there are no bent or broken pins on the CPU.**

If any pins are damaged, do not continue with the upgrade, and return the upgrade kit to the point of purchase.

**3. Check that the thermal pad on the heat sink assembly is undamaged.**

If there is any damage to the thermal pad, do not continue with the upgrade, and return the upgrade kit to the point of purchase. Heat sinks cannot be re-used.

If any components are missing, contact your Sun sales representative.

---

# Server Precheck

---

**Note** – The server must be functioning correctly in order to perform the upgrade.

---

**1. Put the CD-ROM into the optical media tray.**

If the server does not have an optical media tray, see Appendix A.

**2. Run the utility in pre-check mode.**

- If the CD-ROM is mounted locally, type:

```
# /cdrom/cdrom0/Tools/precheck
The current system CPU information is correct.
The following configurations are supported:
1X 1002 MHZ
1X 1280 MHZ
2X 1002 MHZ (current configuration)
2X 1280 MHZ
Utility Version: 1.1
```

- If the CD-ROM is mounted remotely, type:

```
# /remotecdrom/Tools/precheck -p /remotecdrom/Tools
```

This command inspects the FRU ID information held for the system board and processor configuration, and tells you what upgrade options are available. It also reports any problems with the existing configuration.

### 3. If necessary, you may inspect the current FRU ID system board information as follows:

- If the CD-ROM is mounted locally, in a bourne shell type:

```
# LD_LIBRARY_PATH=/cdrom/cdrom0/Tools/lib:$LD_LIBRARY_PATH
# export LD_LIBRARY_PATH
# prtfru system-board
/frutree/chassis/MB?Label=MB/system-board (container)
  SEGMENT: SD
    /ManR
      /ManR/UNIX_Timestamp32: Thursday March  6 01:12:40 GMT 2003
      /ManR/Fru_Description: FRUID, INSTR, M'BD, 1X1.002GHZ
      /ManR/Manufacture_Loc: Hsinchu, Taiwan
      /ManR/Sun_Part_No: 3753149
      /ManR/Sun_Serial_No: 000111
      /ManR/Vendor_Name: Mitac International
      /ManR/Initial_HW_Dash_Level: 03
      /ManR/Initial_HW_Rev_Level: 0F
      /ManR/Fru_Shortname: MOTHERBOARD
      /SpecPartNo: 885-0138-08
```

- If the CD-ROM is mounted remotely, in a bourne shell type:

```
# LD_LIBRARY_PATH=/remotecdrom/Tools/lib:$LD_LIBRARY_PATH
# export LD_LIBRARY_PATH
# prtfru system-board
/frutree/chassis/MB?Label=MB/system-board (container)
  SEGMENT: SD
    /ManR
    /ManR/UNIX_Stamp32: Thursday March 6 01:12:40 GMT 2003
    /ManR/Fru_Description: FRUID, INSTR, M'BD, 1X1.002GHZ
    /ManR/Manufacture_Loc: Hsinchu, Taiwan
    /ManR/Sun_Part_No: 3753149
    /ManR/Sun_Serial_No: 000111
    /ManR/Vendor_Name: Mitac International
    /ManR/Initial_HW_Dash_Level: 03
    /ManR/Initial_HW_Rev_Level: 0F
    /ManR/Fru_Shortname: MOTHERBOARD
    /SpecPartNo: 885-0138-08
```

#### 4. Ensure that your intended upgrade is supported. For details, refer to “Supported Upgrade Paths” on page 2.

Some configurations may require a second upgrade kit.

---

## Preparing the Server

This section describes how to shut down the server and access the CPU.

### Antistatic Precautions



---

**Caution – War** an antistatic wrist strap that is correctly connected to the chassis at all times. For complete antistatic precautions, refer to the *Sun Fire V210 and V240 Servers Parts Replacement Manual* (part number 817-0743-xx).

---

1. **Attach the antistatic strap as directed on the packaging. If you are using a strap that connects with a fastener, attach it to the grounding stud located on the partition inside the server, and the other end to your wrist.**

See FIGURE 2-1.

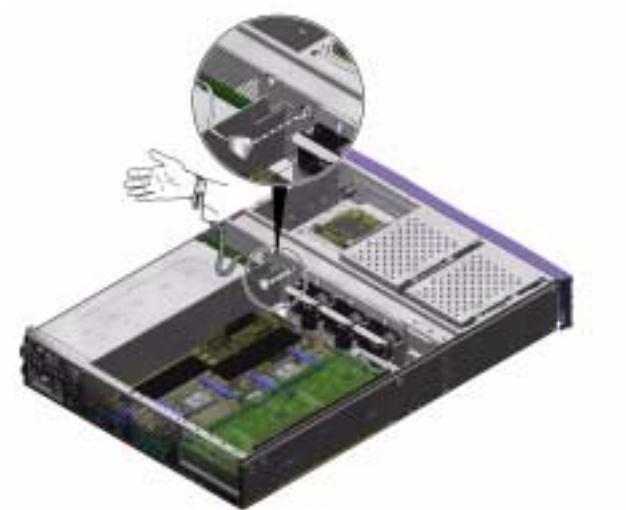

FIGURE 2-1 Antistatic wrist strap attaching point

## ▼ To Shut Down the Server

### 1. Type:

```
# touch /reconfigure  
# shutdown -y -g0 -i5
```

### 2. Disconnect the server from its power source.

Remove the power cable from the power supply unit(s). Ensure that the server is grounded. Two grounding studs are located at the rear of the chassis.

## ▼ To Open the Lid

### 1. Locate the latches at the back of the server, and release them (see FIGURE 2-2).

2. Undo the captive Phillips screw in the catch on top of the server (see FIGURE 2-2).



FIGURE 2-2 Lifting the lid

3. Pull the lever to release the catch and lift the lid up, pulling from the center and one corner of the lid.

The lid hinges forward to lay flush against the front section of the server.

4. Sun Fire V240 server only: remove the air baffle.

The air baffle is not part of the lid assembly, but you must remove it to gain access to the components that are in the back section of the server.

---

**Note** – Complete instructions for opening and removing the server's lid assembly are contained in the *Sun Fire V210 and V240 Servers Parts Replacement Manual*.

---

---

# CPU Upgrades

This section describes how to remove and install a CPU.



---

**Caution** – The CPU/heatsink assembly may be very hot. Let it cool before continuing with this procedure.

---

## ▼ To Remove a CPU

1. **Disconnect the CPU fan cables from the system board.**
2. **Unclip the CPU heat sink.**  
Push down on each clip, then angle the clip away from the fastener. Once both clips are unfastened, unhook them from the opposite end of the heat sink.
3. **Carefully lift the heat sink away from the CPU and out of the server.**  
Make sure that the CPU does not remain attached to the bottom of the heat sink when you lift it out.

---

**Note** – The old heat sink cannot be re-used. Discard it.

---

4. **Release the CPU from its socket.**  
Pull the retaining lever upright to release the CPU.
5. **Store the old CPU in an antistatic enclosure and return it to the customer.**

## ▼ To Install a CPU

1. **Remove all packaging from the CPU upgrade kit.**
2. **On the server's system board, ensure that the CPU retaining lever is in the upright position.**
3. **Align the new CPU with the socket, using the missing corner pin as a guide.**

#### 4. Carefully place the CPU in the socket.

When the CPU is placed correctly, it lies flush in the socket. It is possible to misalign the CPU by a whole row of pins: ensure this has not happened when you install a new CPU. See FIGURE 2-3.

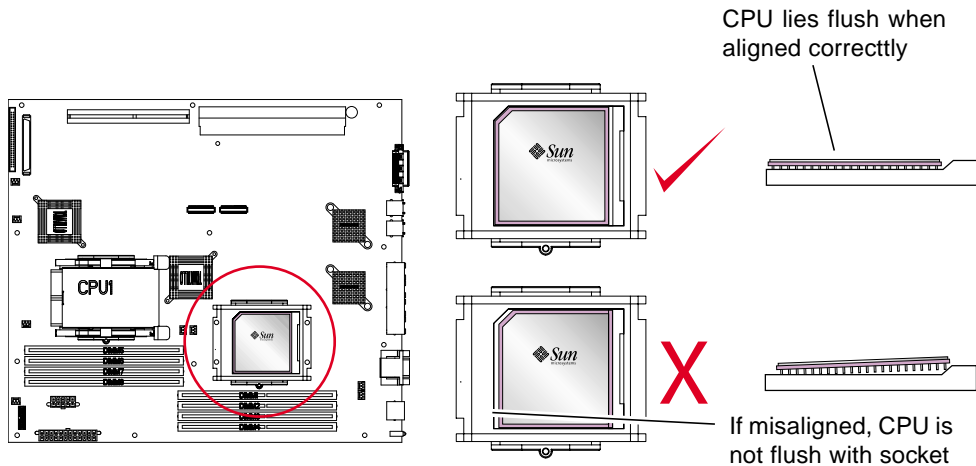

FIGURE 2-3 CPU alignment

#### 5. Secure the CPU in the socket.

Press the retaining lever down so that it is horizontal to the motherboard and trapped by the small clip.

### ▼ To Install the Heat Sink

1. Make sure that there is no scratching or other damage on the new heat sink.
2. Make sure that there is no damage to the thermal pad on the heat sink.
3. Position the replacement heat sink over the appropriate CPU.



---

**Caution** – Once it is located on the CPU, do not move the heat sink. Moving it can damage the thermal pad.

---

#### 4. Fasten the heat sink clips.

- Press and hold the heat sink with one hand and attach the fasteners with the other.

- Fasten one side at a time. Do not allow the heat sink to move or tilt while you are attaching the fasteners.

**5. Reconnect the CPU fan cables.**

See FIGURE 2-4 for the location of the connectors.

---

## Jumper Settings

If the CPU upgrade increases the processor speed, you must change the setting of JP4 on the system board. If you install a faster processor, you must add a jumper, which is supplied in the box with the CPU. See FIGURE 2-4 for the location of JP4 on the system board.

If the jumper setting does not match the processor speed, the server may not function normally.

**TABLE 2-1** JP4: Required Jumper Setting Per Processor Speed

| Pin No. | 1 GHz      | 1.28 GHz   |
|---------|------------|------------|
| 12-11   | Not Fitted | Not Fitted |
| 10-9    | Not Fitted | Not Fitted |
| 8-7     | Not Fitted | Not Fitted |
| 6-5     | Not Fitted | Not Fitted |
| 4-3     | Not Fitted | Fitted     |
| 2-1     | Fitted     | Fitted     |

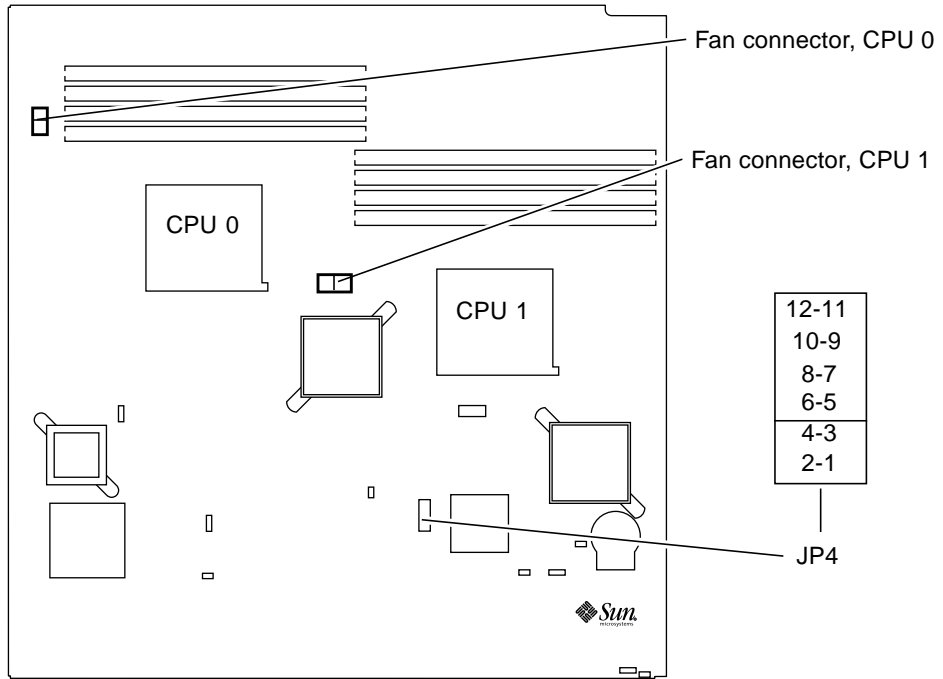

**FIGURE 2-4** Location of JP4

## Memory

There are four memory module sockets per processor on the server's system board. Memory is supplied by Sun in paired DIMMs. Ensure that you use the DIMM pairs as supplied and do not mix them.

For a list of available memory options, see the Sun Fire V210 and V240 Administration Guide.

# Memory Configuration Rules

When you install memory into a Sun Fire V210 or V240 server, follow the configuration rules below:

- DIMMs must be identical.
- Install two DIMMs at a time per CPU.
- Maintain an equal amount of memory for each CPU.
- Use a minimum of two matched DIMMs per CPU.
- Do not mix DIMM capacities.

---

## Part Number Labels

When you have completed a CPU upgrade, you need to indicate the change by updating the appropriate part number. You do this by applying one label to the system board and another to the outside of the server's bezel. The labels you need are contained on a sheet in the upgrade kit.

- System board labels are identified as A, B, C or D.
- Bezel labels are identified as W,X,Y or Z.

All upgrades and the labels you need for each are summarized in TABLE 2-2.

**TABLE 2-2** Upgrade identification labels

| Old part number          | New part number          | Label ID | Server                         |
|--------------------------|--------------------------|----------|--------------------------------|
| single 1GHz: 375-3119    | dual 1GHz: 375-3122      | B, W     | Sun Fire V210 server           |
| single 1GHz: 375-3149    | dual 1GHz: 375-3150      | C, X     | Sun Fire V210 and V240 servers |
| single 1GHz: 375-3149    | single 1.28GHz: 375-3178 | D, Z     | Sun Fire V240 server           |
| single 1GHz: 375-3149    | dual 1.28GHz: 375-3120   | A, Y     | Sun Fire V240 server           |
| dual 1GHz: 375-3150      | single 1.28GHz: 375-3178 | D, Z     | Sun Fire V240 server           |
| dual 1GHz: 375-3150      | dual 1.28GHz: 375-3120   | A, Y     | Sun Fire V240 server           |
| single 1.28GHz: 375-3178 | dual 1.28GHz: 375-3120   | A, Y     | Sun Fire V240 server           |

## ▼ To Apply the System Board Upgrade Notification Label

1. Apply the system board label on top of the old one, leaving the revision number from the old sticker visible. (The revision number is the final two digits of the sequence xxx-xxxx-xx.) See FIGURE 2-5.

The system board label is located under the PCI cards, if any are fitted. For PCI card removal procedures, refer to the *Sun Fire V210 and V240 Servers Parts Replacement Manual* (817-0743-xx).

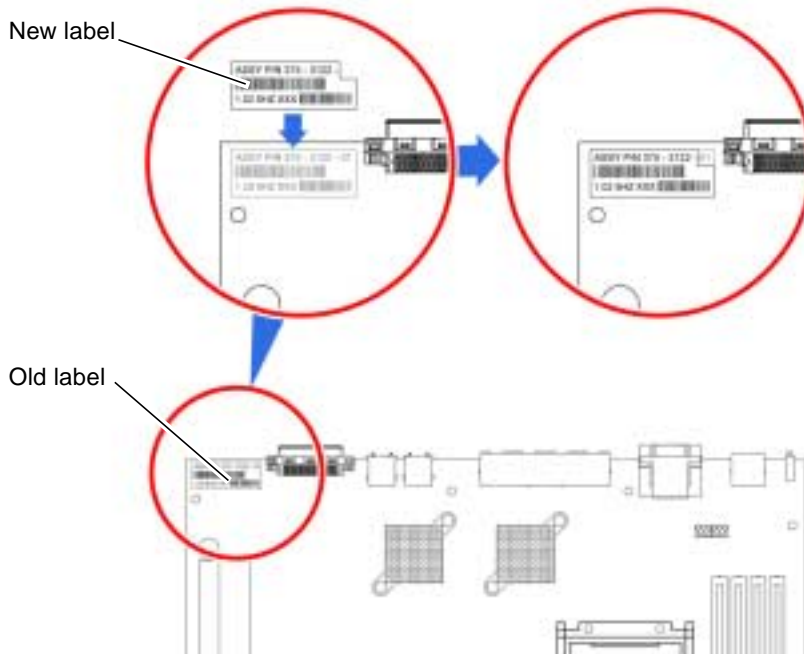

FIGURE 2-5 Placing the system board label

---

## Closing the Server Lid

1. **Sun Fire V240 server only: replace the air baffle.**

This is essential to ensure correct cooling of the server.

2. **Rotate the lid back to its closed position.**

Make sure that the lid latches in to its closed position.

3. **Tighten the captive screw in the catch on the lid.**

4. **Secure the lid using the clips on the outside of the server.**

5. **Reconnect all power and data cables.**

6. **Power the server on.**

For information about powering the server on, refer to the *Sun Fire V210 and V240 Servers Installation Guide* (816-4825-xx).

---

## Verify Installation

1. **Run Power On Self Test to verify that the new components function correctly.**

---

**Note** – POST is not run by default. Before powering on, set `bootmode` to `diag`.

---

2. **At the OK prompt, type:**

```
ok> boot -r
```

This ensures that the PICL data is valid for the new configuration.

3. Apply the system upgrade notification label to the top of the server's bezel.



FIGURE 2-6 Applying the system label to the bezel

---

## Updating the FRU ID

When you have installed the hardware, update the dynamic area of the server's FRU ID to capture the changes you made. You do this by running the update utility contained on the CD-ROM that is included in the CPU upgrade kit.

### ▼ To Run the Update Utility

1. Insert the CD-ROM into the server's optical media drive.

If your server does not contain an optical media drive, insert the CD-ROM into a system that the server can access over the network. See Appendix A.

2. Run the update utility.

- If the CD-ROM is mounted locally, type:

```
# /cdrom/cdrom0/Tools/update
```

- If the CD-ROM is mounted remotely, type:

```
# /remotecdrom/Tools/update -p /remotecdrom/Tools
```

### 3. Confirm that the update was successful by typing one of the following commands.

- If the CD-ROM is mounted locally, in a bourne shell type:

```
# LD_LIBRARY_PATH=/cdrom/cdrom0/Tools/lib:$LD_LIBRARY_PATH
# export LD_LIBRARY_PATH
# prtfru system-board
/frutree/chassis/MB?Label=MB/system-board (container)
  SEGMENT: FE
    /MaintenanceR (1 iterations)
    /MaintenanceR[0]
    /MaintenanceR[0]/UNIX_Timestamp32: Wednesday December 3
16:33:52 GMT 2003
    /MaintenanceR[0]/New_Description: UPGRADE,2X1.002GHZ,CPU
    /MaintenanceR[0]/New_Sun_Part_No: 3753150
  SEGMENT: SD
    /ManR
    /ManR/UNIX_Timestamp32: Thursday March 6 01:12:40 GMT 2003
    /ManR/Fru_Description: FRUID, INSTR, M'BD, 1X1.002GHZ
    /ManR/Manufacture_Loc: Hsinchu, Taiwan
    /ManR/Sun_Part_No: 3753149
    /ManR/Sun_Serial_No: 000111
    /ManR/Vendor_Name: Mitac International
    /ManR/Initial_HW_Dash_Level: 03
    /ManR/Initial_HW_Rev_Level: 0F
    /ManR/Fru_Shortname: MOTHERBOARD
    /SpecPartNo: 885-0138-08
```

---

**Note** – SEGMENT: FE is added.

---

- If the CD-ROM is mounted remotely, in a bourne shell type:

```
# LD_LIBRARY_PATH=/remotecdrom/Tools/lib:$LD_LIBRARY_PATH
# export LD_LIBRARY_PATH
# prtfru system-board
/frutree/chassis/MB?Label=MB/system-board (container)
  SEGMENT: FE
    /MaintenanceR (1 iterations)
    /MaintenanceR[0]
    /MaintenanceR[0]/UNIX_Timestamp32: Wednesday December 3
16:33:52 GMT 2003
    /MaintenanceR[0]/New_Description: UPGRADE,2X1.002GHZ,CPU
    /MaintenanceR[0]/New_Sun_Part_No: 3753150
  SEGMENT: SD
    /ManR
    /ManR/UNIX_Timestamp32: Thursday March 6 01:12:40 GMT 2003
    /ManR/Fru_Description: FRUID,INSTR,M'BD,1X1.002GHZ
    /ManR/Manufacture_Loc: Hsinchu,Taiwan
    /ManR/Sun_Part_No: 3753149
    /ManR/Sun_Serial_No: 000111
    /ManR/Vendor_Name: Mitac International
    /ManR/Initial_HW_Dash_Level: 03
    /ManR/Initial_HW_Rev_Level: 0F
    /ManR/Fru_Shortname: MOTHERBOARD
    /SpecPartNo: 885-0138-08
```

---

**Note** – SEGMENT: FE is added.

---

## Netra 240 Server

---

This chapter describes how to install a new 1.28 GHz CPU and heat sink assembly in the Netra 240 server.

After completing this procedure, you will have upgraded a single 1.28GHz CPU server to a dual 1.28GHz CPU server.

- The chapter contains the following sections:
- “Tools Required” on page 19
- “Inventory Check” on page 20
- “Server Precheck” on page 20
- “This section describes how to shut down the server and access the CPU.” on page 22
- “Part Number Labels” on page 30
- “Updating the FRU ID” on page 32

---

## Tools Required

You will need the following two screwdrivers during the installation:

- No. 1 Phillips screwdriver
- No. 2 Phillips screwdriver

---

# Inventory Check

**1. Check that all of the following components are present in the upgrade kit:**

- CPU
- Heat sink assembly
- Jumper (2mm)
- Documentation
- CD-ROM
- Anti-static wrist strap
- Part number label sheet

**2. Ensure that there are no bent or broken pins on the CPU.**

If any pins are damaged, do not continue with the upgrade, and return the upgrade kit to the point of purchase.

**3. Check that the thermal pad on the heat sink assembly is undamaged.**

If there is any damage to the thermal pad, do not continue with the upgrade, and return the upgrade kit to the point of purchase. Heat sinks cannot be re-used.

If any components are missing, contact your Sun sales representative.

---

# Server Precheck

---

**Note** – The server must be functioning correctly in order to perform the upgrade.

---

**1. Put the CD-ROM into the optical media tray.**

If the server does not have an optical media tray, see Appendix A.

**2. Run the utility in pre-check mode.**

- If the CD-ROM is mounted locally, type:

```
# /cdrom/cdrom0/Tools/precheck
The current system CPU information is correct.
The following configurations are supported:
1X 1280 MHZ (current configuration)
2X 1280 MHZ
Utility Version: 1.1
```

- If the CD-ROM is mounted remotely, type:

```
# /remotecdrom/Tools/precheck -p /remotecdrom/Tools
```

This command inspects the FRU ID information held for the system board and processor configuration, and tells you what upgrade options are available.

It also reports any problems with the existing configuration.

### 3. If necessary, you may inspect the current FRU ID system board information as follows:

- If the CD-ROM is mounted locally, in a bourne shell type:

```
# LD_LIBRARY_PATH=/cdrom/cdrom0/Tools/lib:$LD_LIBRARY_PATH
# export LD_LIBRARY_PATH
# prtfru system-board
/frutree/chassis/MB?Label=MB/system-board (container)
SEGMENT: SD
  /ManR
  /ManR/UNIX_Stamp32: Wed Feb 19 09:00:01 GMT 2003
  /ManR/Fru_Description: FRUID, INSTR, M'BD, 1X1.28GHZ, CPU
  /ManR/Manufacture_Loc: Hsinchu, Taiwan
  /ManR/Sun_Part_No: 3753178
  /ManR/Sun_Serial_No: 000706
  /ManR/Vendor_Name: Mitac International
  /ManR/Initial_HW_Dash_Level: 02
  /ManR/Initial_HW_Rev_Level: 0F
  /ManR/Fru_Shortname: MOTHERBOARD
  /SpecPartNo: 885-0076-11
```

- If the CD-ROM is mounted remotely, in a bourne shell type:

```
# LD_LIBRARY_PATH=/remotecdrom/Tools/lib:$LD_LIBRARY_PATH
# export LD_LIBRARY_PATH
# prtfru system-board
/frutree/chassis/MB?Label=MB/system-board (container)
  SEGMENT: SD
    /ManR
      /ManR/UNIX_Stamp32: Wed Feb 19 09:00:01 GMT 2003
      /ManR/Fru_Description: FRUID, INSTR, M'BD, 1X1.28GHZ, CPU
      /ManR/Manufacture_Loc: Hsinchu, Taiwan
      /ManR/Sun_Part_No: 3753178
      /ManR/Sun_Serial_No: 000706
      /ManR/Vendor_Name: Mitac International
      /ManR/Initial_HW_Dash_Level: 02
      /ManR/Initial_HW_Rev_Level: 0F
      /ManR/Fru_Shortname: MOTHERBOARD
      /SpecPartNo: 885-0076-11
```

#### 4. Ensure that your intended upgrade is supported. For details, refer to “Supported Upgrade Paths” on page 2.

Some configurations may require a second upgrade kit.

---

## Preparing the Server

This section describes how to shut down the server and access the CPU.

---

**Note** – Before installing the CPU and heat sink assembly, refer to the *Netra 240 Server Service Manual* (817-2699-xx) for the latest installation and service instructions. You can download the latest Netra 240 server documentation from this web site: <http://www.sun.com/documentation/>.

---

---

**Note** – When installing a second CPU to your Netra 240 server, you must also install an additional pair of identical memory DIMMs. Refer to the *Netra 240 Server Service Manual* for installation instructions.

---

# Antistatic Precautions



**Caution** – Wear an antistatic wrist strap that is correctly connected to the chassis at all times. For complete antistatic precautions, refer to the *Netra 240 Server Service Manual*.

## ▼ To Shut Down the Server

**Note** – This procedure describes how to power down the server using the `shutdown` command. For additional power down instructions, refer to the *Netra 240 Server Service Manual*.

1. Notify users that the server will be powered down.
2. Back up server files and data.
3. Grip the bezel at the two finger holds and rotate it down to its open position (FIGURE 3-1).

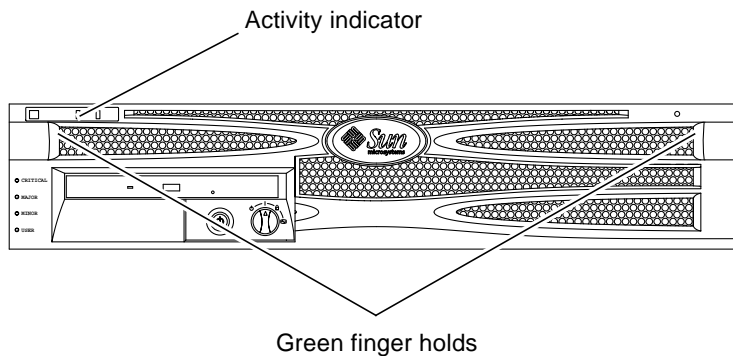

FIGURE 3-1 Finger holds on bezel

4. Ensure that the rotary switch is in the Normal or Diagnostics position (FIGURE 3-2).

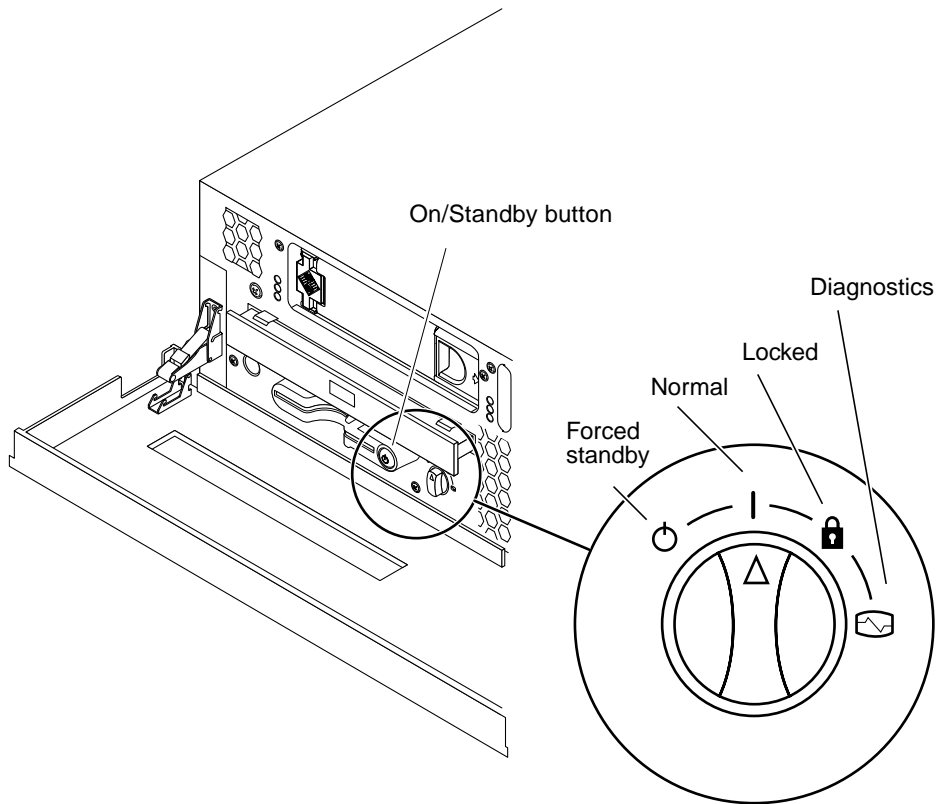

FIGURE 3-2 Rotary switch positions

- From a command line, log into the Netra 240 and shut the server down. Type:

```
# touch /reconfigure
# /usr/sbin/shutdown -y -g0 -i5
```

- Wait for the front panel green Activity indicator to go out and the server fans to stop spinning.

See FIGURE 3-1 for the location of the Activity LED.

- Disconnect both power input cables.

This is the only way to remove power from the server. Electrical power is present when the server is in Standby mode.



---

**Caution** – As long as the power input cables are connected, potentially hazardous energy is present inside the server.

---

8. **Disconnect all data cables from the rear of the server.**
9. **Close the bezel.**
10. **If the server is installed in a rack, remove server from the rack and place it on a suitable work table.**

## ▼ To Access the Internal Components

1. **Loosen the captive screw in the back of the lid (FIGURE 3-3).**

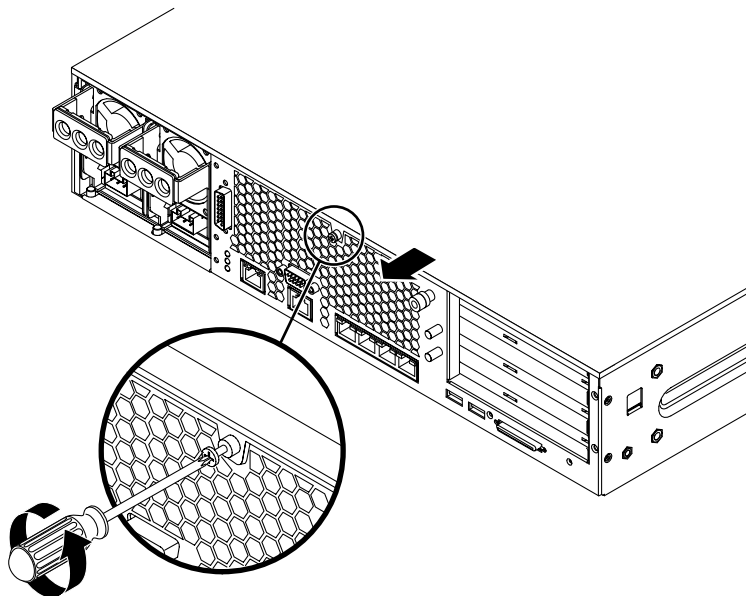

**FIGURE 3-3** Removing the server lid

2. **Grasp the lid at the sides and slide it toward the back of the server, then lift it up and away from the server.**
3. **Loosen the two captive screws on the rotating service module and lower the module (FIGURE 3-4).**

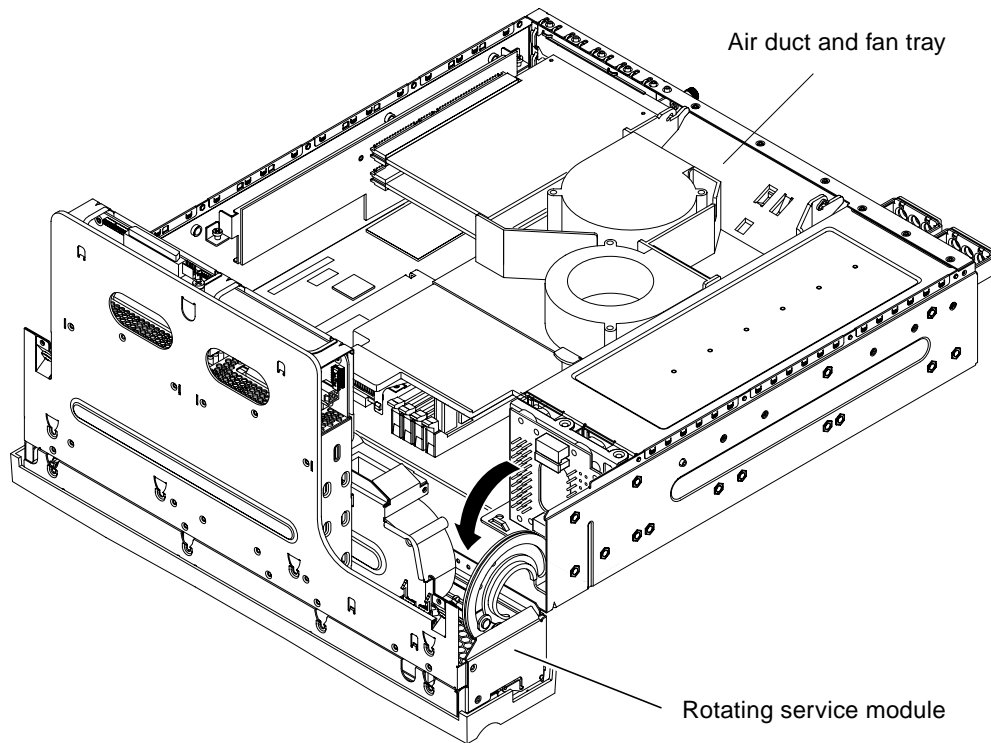

FIGURE 3-4 Lowering the rotating service module



---

**Caution** – When the Netra 240 server is removed from the rack and placed on a table for servicing, do not pull the server too far out with the rotating service module down or the server could tip over.

---

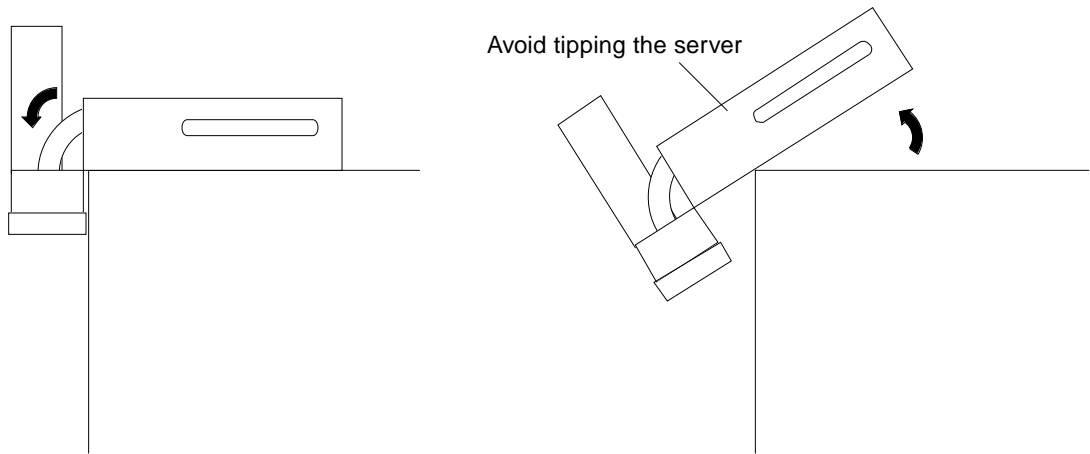

**FIGURE 3-5** Avoiding the Netra 240 server tip hazard

- 4. Avoid electrostatic discharge by attaching one end of the antistatic strap to the grounding point inside the server, and the other end to your wrist (FIGURE 3-6).**

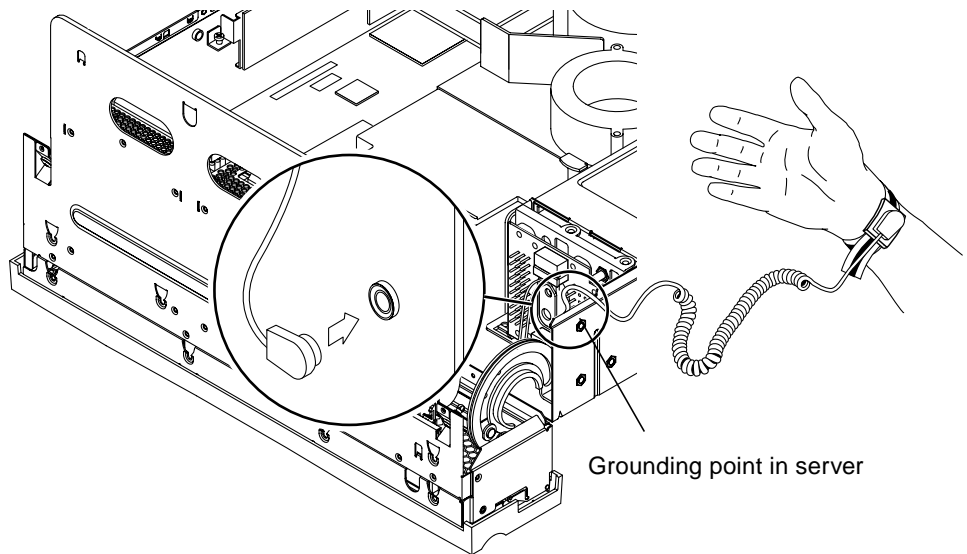

**FIGURE 3-6** Grounding point in the server



---

**Caution** – Wear an antistatic wrist strap that is correctly connect to the chassis at all times during the CPU installation. For complete antistatic precautions, refer to the Netra 240 Server Service Manual.

---

5. **To gain access to the components beneath the air duct and rear fan assembly (FIGURE 3-4), push the tab on the right of the assembly, then rotate it up and out of the way.**

---

## CPU Upgrades

This section describes how to install a CPU and heatsink.

### ▼ To Install the CPU

1. **Remove all packaging from the CPU.**
2. **On the open CPU socket, lift the retaining lever upright.**
3. **Align the new CPU with the socket, using the missing corner pin as a guide.**
4. **Carefully place the CPU in the socket.**

---

**Note** – When the CPU is placed correctly, it lies flush in the socket. It is possible to misalign the CPU by a whole row of pins. Ensure that the CPU has been placed properly before securing it in the socket. See FIGURE 2-3.

---

5. **Lower the retaining lever downward to secure the CPU in the socket.**

### ▼ To Install the Heat Sink

1. **Remove all packaging from the heat sink assembly.**
2. **Using a No. 1 Phillips screwdriver, remove the screws securing the heat sink fans (FIGURE 3-7).**

There are two screws securing each fan.

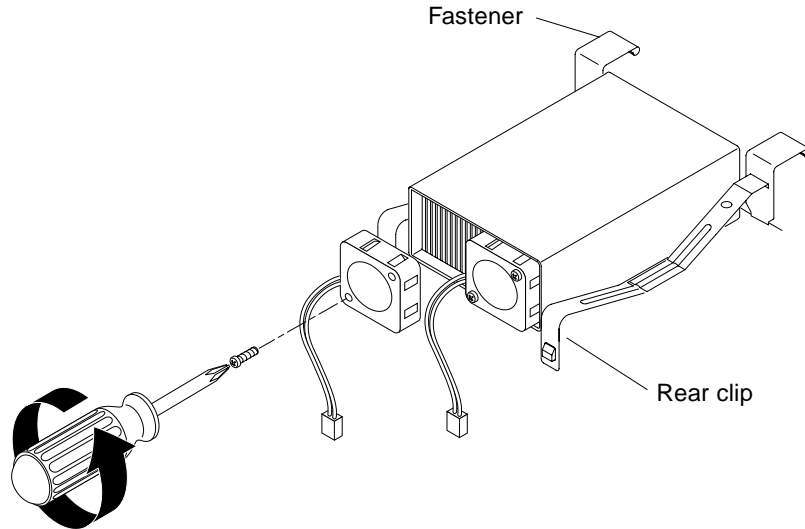

FIGURE 3-7 Removing the fans from the heat sink assemblies

3. Carefully place the heat sink on top of the CPU so that the copper plate sits in the housing frame.
4. Fasten the rear clips (FIGURE 3-7).
5. Push down on the fasteners to clip them to the housing (FIGURE 3-7).

---

## Jumper Settings

Do not change jumper JP4 on the system board. You do not need to change the setting of any jumpers on the system board after installing a CPU in the Netra 240 server.

---

# Part Number Labels

When you have completed a CPU upgrade, you need to indicate the change by updating the appropriate part number. You do this by applying one label to the system board and another to the outside of the server's bezel. The labels you need are contained on a sheet in the upgrade kit.

- System board labels are identified as A, B, C or D.
- Bezel labels are identified as W,X,Y or Z.

All upgrades and the labels you need for each are summarized in TABLE 3-1.

**TABLE 3-1** Upgrade identification labels

| Old part number           | New part number         | Label ID |
|---------------------------|-------------------------|----------|
| single 1.28 GHz: 375-3178 | dual 1.28 GHz: 375-3120 | A, Y     |

- Apply the system label to the top of the server's bezel.
- Apply the system board label over the old one, leaving the revision number from the old sticker visible. (The revision number is the final two digits of the sequence xxx-xxxx-xx.)

---

# Reassembling and Reinstalling the Server

After installing the CPU in the server, reassemble and reinstall the server into the rack.

---

**Note** – Do not change jumper JP4 on the system board. You do not need to change the setting of any jumpers on the system board after installing a CPU in the Netra 240 server.

---

1. **Lower and close the air duct and fan assembly.**
2. **Raise the rotating service module.**

Tighten the two captive screws to secure the module in place (FIGURE 3-4).

### 3. Install the server lid.



---

**Caution** – Install the server lid before connecting the DC power input cables or powering the server on.

---

### 4. Reinstall the server into the rack.

Refer to the *Netra 240 Server Installation Manual* (817-2698-xx) for rack installation instructions.

### 5. Reconnect all data and power cables.

### 6. Power the server on.

For information about powering the server on, refer to the *Netra 240 Server Service Manual*.

---

## Verify Installation

### 1. Run POST to ensure the hardware components were installed correctly.

---

**Note** – POST is not run by default. Before powering on, set bootmode to diag.

---

### 2. At the OK prompt, type:

```
ok> boot -r
```

### 3. Apply the system upgrade notification label to the top of the server's bezel.

---

# Updating the FRU ID

When you have installed the hardware, update the dynamic area of the server's FRU ID to capture the changes you made. You do this by running the update utility contained on the CD-ROM that is included in the CPU upgrade kit.

## ▼ To Run the Update Utility

### 1. Insert the CD-ROM into the server's optical media drive.

If your server does not contain an optical media drive, insert the CD-ROM into a system that the server can access over the network. See Appendix A.

### 2. Run the update utility.

- If the CD-ROM is mounted locally, type:

```
# /cdrom/cdrom0/Tools/update
```

- If the CD-ROM is mounted remotely, type:

```
# /remotecdrom/Tools/update -p /remotecdrom/Tools
```

### 3. Confirm that the update was successful:

- If the CD-ROM is mounted locally, in a bourne shell type:

```
# LD_LIBRARY_PATH=/cdrom/cdrom0/Tools/lib:$LD_LIBRARY_PATH
# export LD_LIBRARY_PATH
# prtfru system-board
/frutree/chassis/MB?Label=MB/system-board (container)
  SEGMENT: FE
    /MaintenanceR (1 iterations)
    /MaintenanceR[0]
    /MaintenanceR[0]/UNIX_Stamp32: Wednesday December 3
16:33:52 GMT 2003
    /MaintenanceR[0]/New_Description: UPGRADE,2X1.28GHZ,CPU
    /MaintenanceR[0]/New_Sun_Part_No: 3753120
  SEGMENT: SD
    /ManR
    /ManR/UNIX_Stamp32: Wed Feb 19 09:00:01 GMT 2003
    /ManR/Fru_Description: FRUID, INSTR, M'BD, 1X1.28GHZ, CPU
    /ManR/Manufacture_Loc: Hsinchu, Taiwan
    /ManR/Sun_Part_No: 3753178
    /ManR/Sun_Serial_No: 000736
    /ManR/Vendor_Name: Mitac International
    /ManR/Initial_HW_Dash_Level: 02
    /ManR/Initial_HW_Rev_Level: 0F
    /ManR/Fru_Shortname: MOTHERBOARD
    /SpecPartNo: 885-0076-11
```

---

**Note** – SEGMENT: FE is added.

---

- If the CD-ROM is mounted remotely, in a bourne shell type:

```
# LD_LIBRARY_PATH=/remotecdrom/Tools/lib:$LD_LIBRARY_PATH
# export LD_LIBRARY_PATH
# prtfru system-board
/frutree/chassis/MB?Label=MB/system-board (container)
  SEGMENT: FE
    /MaintenanceR (1 iterations)
    /MaintenanceR[0]
    /MaintenanceR[0]/UNIX_Timestamp32: Wednesday December 3
16:33:52 GMT 2003
    /MaintenanceR[0]/New_Description: UPGRADE,2X1.28GHZ,CPU
    /MaintenanceR[0]/New_Sun_Part_No: 3753120
  SEGMENT: SD
    /ManR
    /ManR/UNIX_Timestamp32: Wed Feb 19 09:00:01 GMT 2003
    /ManR/Fru_Description: FRUID,INSTR,M'BD,1X1.28GHZ,CPU
    /ManR/Manufacture_Loc: Hsinchu,Taiwan
    /ManR/Sun_Part_No: 3753178
    /ManR/Sun_Serial_No: 000736
    /ManR/Vendor_Name: Mitac International
    /ManR/Initial_HW_Dash_Level: 02
    /ManR/Initial_HW_Rev_Level: 0F
    /ManR/Fru_Shortname: MOTHERBOARD
    /SpecPartNo: 885-0076-11
```

---

**Note** – SEGMENT: FE is added.

---

## For Host Servers Without a Built-In Optical Media Drive

---

This section tells you how to mount an optical media drive from a remote host if one is not fitted to the host server.

---

**Note** – You can download CPU upgrade utility tools software from [www.sun.com/software/download](http://www.sun.com/software/download).

---

### ▼ To Mount the CD-ROM on a Remote Host

On the *remote host* that has an optical media drive fitted:

1. **Place the CD-ROM in the optical media tray.**
2. **Edit the `/etc/dfs/dfstab` file and add the following entry:**

```
share -F nfs -o ro /cdrom/cdrom0
```

3. **Type:**

```
# shareall
```

4. **If this is the first time that the NFS server is being shared, type:**

```
# /etc/init.d/nfs.server start
```

Type the following command to verify that the CD-ROM is being shared:

```
# showmount -e <server_name>
```

On the *local server* (the one you are upgrading):

**1. Create a mount point. Type:**

```
# mkdir /remotecdrom
```

**2. Mount the CD-ROM. Type:**

```
# mount -rF nfs <server_name>:/cdrom/cdrom0 /remotecdrom
```

**3. Confirm that the remote CD-ROM is now available. Type:**

```
# ls /remotecdrom/Tools  
lib      precheck  sbin      update
```

## Upgrade Problems

---

If the inventory check reveals damage to the CPU or heatsink, return the upgrade kit to the customer. Do not attempt the upgrade procedure.

If the system board becomes damaged during the upgrade process, or POST fails for any reason after the upgrade, replace the complete upgraded system board with a complete system board from Sun that corresponds to the upgrade you attempted:

- F375-3120
- F375-3122
- F375-3150
- F375-3178

Return the faulty system board to Sun.



# Upgrade Checklist

As you carry out the upgrade, tick off each task in the procedure to ensure it was carried out correctly.

**TABLE C-1** Upgrade checklist

| Task  | Sun Fire V210/V240                    | Netra 240                             | Done                     |
|---|---------------------------------------|---------------------------------------|--------------------------|
| Check supplied components                       | “Inventory Check” on page 4           | “Inventory Check” on page 20          | <input type="checkbox"/> |
| Precheck server                                 | “Server Precheck” on page 4           | “Server Precheck” on page 20          | <input type="checkbox"/> |
| Install new CPU(s)                              | “CPU Upgrades” on page 9              | “CPU Upgrades” on page 28             | <input type="checkbox"/> |
| Install new heat sink(s)                        | “To Install the Heat Sink” on page 10 | “To Install the Heat Sink” on page 28 | <input type="checkbox"/> |
| Install correct JP4 jumper(s)                   | “Jumper Settings” on page 11          | “Jumper Settings” on page 29          | <input type="checkbox"/> |
| Apply new FRU part number label to system board | “Part Number Labels” on page 13       | “Part Number Labels” on page 30       | <input type="checkbox"/> |
| Verify installation with POST                   | “Verify Installation” on page 15      | “Verify Installation” on page 31      | <input type="checkbox"/> |
| Update FRUID                                    | “Updating the FRU ID” on page 16      | “Updating the FRU ID” on page 32      | <input type="checkbox"/> |
| Apply notification label to front bezel         | “Part Number Labels” on page 13       | “Part Number Labels” on page 30       | <input type="checkbox"/> |



## Upgrade Utility Download

---

This section describes how to download the utility software over the internet in cases where the CD-ROM or optical media drive is not available.

### ▼ To download the utility software

1. **Go to** [http://www.sun.com/servers/entry/cpu\\_upgrade\\_utility.html](http://www.sun.com/servers/entry/cpu_upgrade_utility.html)
2. **Download the file as directed.**
3. **If necessary, transfer the downloaded zip file to the server being upgraded.**
4. **Type:**

```
# mkdir /upgradeutility
```

5. **Copy the downloaded zip file to the `upgradeutility` directory.**
6. **Change to the `upgradeutility` directory. Type:**

```
# cd /upgradeutility
```

7. **Unzip the file. Type:**

```
# unzip <downloaded_file>
```

You can now access the utility from the `/upgradeutility/Tools` area.

