

HP StorageWorks Disk System 2120 User's Guide

Edition E0305
Order No. 5697-5367
Printed in U.S.A.



Notice

© Hewlett-Packard Company, 2004-2005. All rights reserved.

Hewlett-Packard Company makes no warranty of any kind with regard to this document, including, but not limited to, the implied warranties of merchantability and fitness for a particular purpose. Hewlett-Packard shall not be liable for errors contained herein or for incidental or consequential damages in connection with the furnishing, performance, or use of this material.

This document contains proprietary information, which is protected by copyright. No part of this document may be photocopied, reproduced, or translated into another language without the prior written consent of Hewlett-Packard. The information contained in this document is subject to change without notice.

Warranty

If you have any questions about the warranty for this product, contact your dealer or local Hewlett-Packard sales representative.

Safety Notices

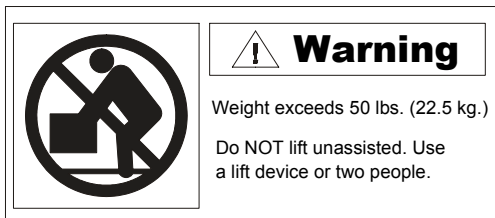

To protect against personal injury and product damage, do not attempt to lift the product without the assistance of another person or lift device.



Components bearing this symbol may be hot to touch.



Components bearing this symbol are fragile. Handle with care.



Components bearing this symbol are susceptible to damage by static electricity. ESD precautions are required.

Operation

The front door should be closed and locked at all times during the operation of this product except when replacing disks.

This product is intended to be operated in a restricted access area.

Service

Maintenance or repair of the backplane and mezzanine boards must be performed by authorized service-trained personnel.

Format Conventions

Denotes

WARNING

A hazard that can cause personal injury



A hazard that can cause hardware or software damage

Note

Significant concepts or operating instructions

this font

Text to be typed verbatim: all commands, path names, and file names. Also menu and button selections in GUI contexts

this font

Text displayed on the screen

| | |
|---|-----------|
| Overview | 7 |
| Components of the Disk System | 8 |
| Front Panel | 8 |
| Disk Module LEDs | 8 |
| System Power LED | 8 |
| Rear Panel | 9 |
| SCSI ID Switch | 10 |
| Power Connector | 11 |
| Electrical Requirements | 11 |
| AC Site Requirements | 11 |
| Installing the Disk System | 12 |
| Hardware Requirements | 12 |
| Preparing for Installation | 12 |
| Setting the SCSI IDs for the Disk Modules | 13 |
| Installing the Disk System | 14 |
| Connect the SCSI Cables | 14 |
| Connecting the Power Cable | 16 |
| Powering On and Off | 16 |
| Power On the Disk System | 16 |
| Power Off the Disk System | 17 |
| Adding Disk Modules | 18 |
| Add a Disk Module | 18 |
| Configure the new Disk Module | 19 |
| Remove and Replace A Disk Module | 19 |
| Remove a Disk Module | 19 |
| Replace a Disk Module | 20 |
| Remove the Disk System | 21 |
| Setting Up the Hardware Event Monitor (HP-UX Only) | 22 |
| Configuration Overview | 22 |
| Event Notification (HP-UX Only) | 23 |
| Status LEDs | 25 |
| View Disk Status | 26 |
| STM Disk Information: HP-UX | 26 |
| STM Disk Information: MPE/iX 6.5 or Later | 28 |
| Isolating Faults | 30 |
| Reference Information | 32 |
| Product Numbers and Options | 32 |
| Upgrade Disk Products Available | 33 |
| Specifications | 35 |
| Electrical Specifications | 35 |
| Operating Temperatures | 36 |
| Regulatory Statements | 36 |
| Safety Certifications | 36 |
| EMC Compliance | 36 |

| | |
|--|-----------|
| A. FCC Notice for United States | 36 |
| B. Canadian Notice (Avis Canadien) | 37 |
| C. Notice for European Union | 37 |
| D. Notice for France | 37 |
| E. Notice for Japan | 37 |
| F. Harmonics Conformance (Japan)..... | 37 |
| G. BSMI | 38 |
| H. Notice for Germany | 38 |
| Product Web Site | 38 |
| Related Documents | 38 |

| | | |
|-----------|--|----|
| Figure 1 | Disk Module LEDs | 8 |
| Figure 2 | System Power LED. | 9 |
| Figure 3 | Rear View of the Disk System | 9 |
| Figure 4 | Power Button | 9 |
| Figure 5 | SCSI ID Switch Settings. | 10 |
| Figure 6 | AC Power Connector Location. | 11 |
| Figure 7 | SCSI Switch Location. | 13 |
| Figure 8 | SCSI Port Locations | 14 |
| Figure 9 | AC Power Connector Location. | 16 |
| Figure 10 | Power Button Location. | 17 |
| Figure 11 | Installing a Disk Module | 19 |
| Figure 12 | Removing the Disk System | 21 |
| Figure 13 | Sample Hardware Event Notification. | 24 |
| Figure 14 | LED Status Indicators. | 25 |
| Figure 15 | Sample STM Information Log (HP-UX) | 27 |
| Figure 16 | Sample STM Expert Tool Disk Error Log (MPE/iX 6.5 or Later). | 29 |

| | | |
|----------|--|----|
| Table 1 | Disk LED Activity Definitions | 8 |
| Table 2 | System Power LED Activity Definitions | 9 |
| Table 3 | AC Power Requirements | 11 |
| Table 4 | SCSI Switch Setting Definitions | 13 |
| Table 5 | SCSI Address Priority | 14 |
| Table 6 | LED Status Indicators | 25 |
| Table 7 | Troubleshooting Table | 30 |
| Table 8 | Product Numbers | 32 |
| Table 9 | Available Upgrade Disk Modules | 33 |
| Table 10 | Upgrade Products for Hewlett-Packard Systems | 33 |
| Table 11 | Replaceable Parts | 34 |
| Table 12 | Supported HP Cables and Terminators | 34 |
| Table 13 | Physical Dimensions | 35 |
| Table 14 | AC Power Requirements | 35 |
| Table 15 | Environmental Specifications | 35 |

Overview

The HP StorageWorks Disk System 2120 is a 1-EIA unit disk systems capable of accommodating up to four disk modules. It is designed to provide inexpensive, high performance rack-optimized online mass storage for entry-level configurations in three distinct markets: (1) HP servers/workstations, (2) open systems JBODs, and (3) open systems IDACs (Internal Disk Array Controller).

The DS2120 supports U320 drives; however, the U320 drives are supported at a maximum of 160 MB/s speeds.

Connectivity to U320 initiators is supported if the speed of the U320 initiator is set to limit negotiations to U160 speed. The U320 drives do not operate reliably or at acceptable performance levels at U320 speeds and are not supported at those speeds. This is due to limitations within the disk system and not the U320 drive mechanisms.

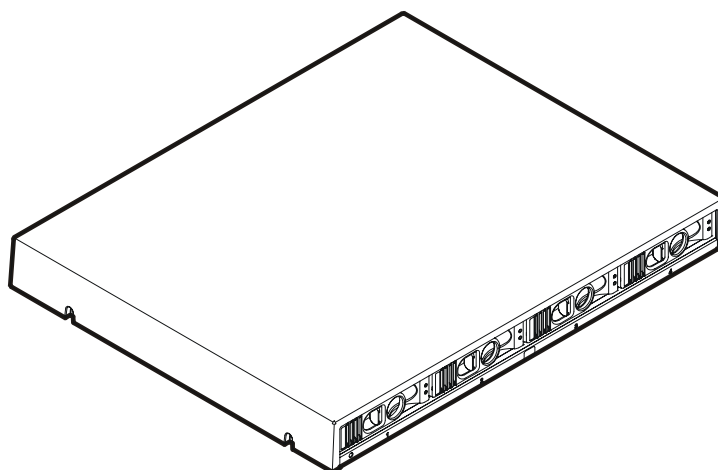

Components of the Disk System

Front Panel

The disk modules can be accessed from the front of the disk system. It can accept up to 4 low profile disk drives. If your storage system contains less than 4 disk modules, the remaining empty slots contain filler panels. These filler panels (part number A6198-60002) ensure that the proper cooling is maintained within the storage system. Remove filler panels only when a disk module is added to the system.

Disk Module LEDs

Each disk module has two LEDs: an amber LED on the top (see Figure 1) and a green LED on the bottom. The amber LED is not operational. The green LED provides disk module status information as listed in Table 6.

FIGURE 1 Disk Module LEDs

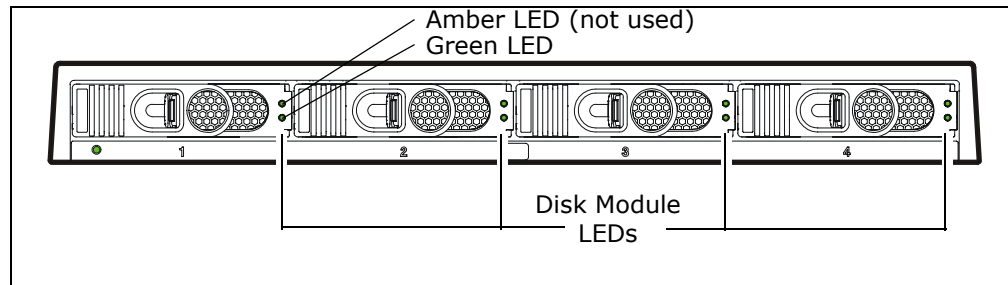

TABLE 1 Disk LED Activity Definitions

| LED Activity | Indication |
|-------------------------------------|---------------------|
| Blinking | Disk activity |
| On solid for approximately 1 second | Bus reset |
| Off | Disk is idle or off |

System Power LED

The System Power LED (see Figure 2) gives diagnostic information about the disk system operation. Refer to Table 2 on page 9 for more information.

FIGURE 2 System Power LED

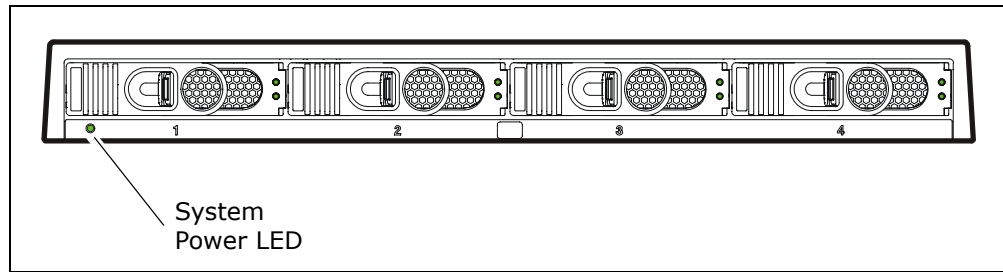

TABLE 2 System Power LED Activity Definitions

| LED Activity | Indication |
|--------------|--|
| Blinking | Malfunction - either a fan is not operating properly or internal voltage is too low. |
| On solid | Disk system is operating properly. |
| Off | Disk system is off. |

Rear Panel

FIGURE 3 Rear View of the Disk System

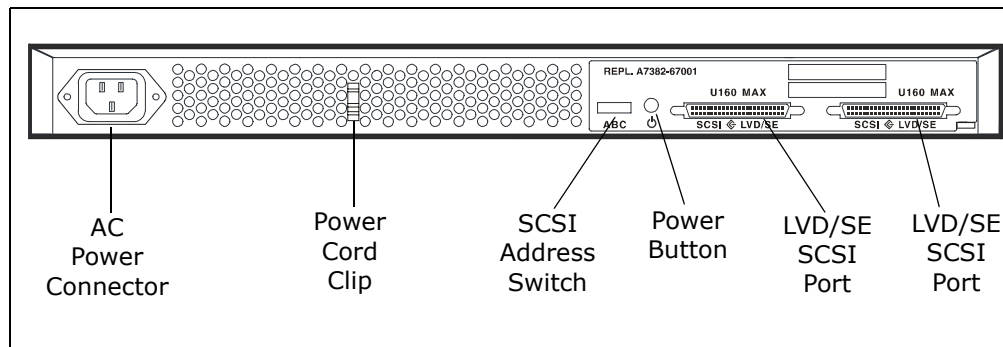
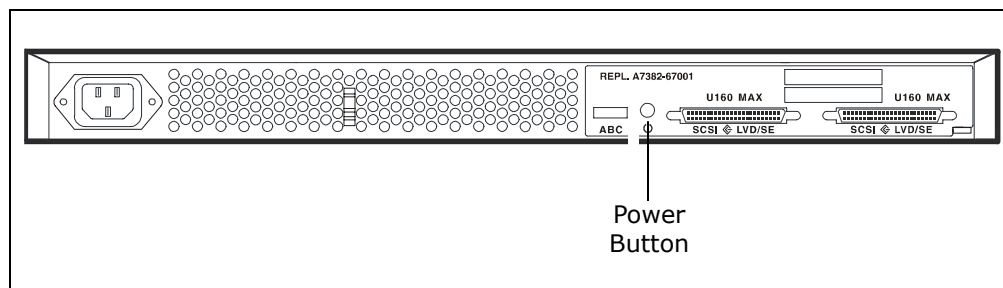

FIGURE 4 Power Button



With the power button in the “ON” position, power is supplied to the disk system.

SCSI ID Switch

The SCSI ID switch sets the address for the disk drives.

There are three possible settings for the SCSI address switch: A, B, and C. Each setting assigns a different *set* of addresses to the disk modules installed in the disk system. For SCSI address switch setting A, the addresses for the installed disk modules are (from left to right, looking at the disk system from the front) 0, 2, 4, and 6. For SCSI address switch setting B, the addresses for the installed disk modules are 8, 10, 12, and 14. For SCSI address switch setting C, the addresses for the installed disk modules are 9, 11, 13, and 15. See Figure 5, below.

SCSI address 7 is reserved for use by the host bus adapter.

FIGURE 5 SCSI ID Switch Settings

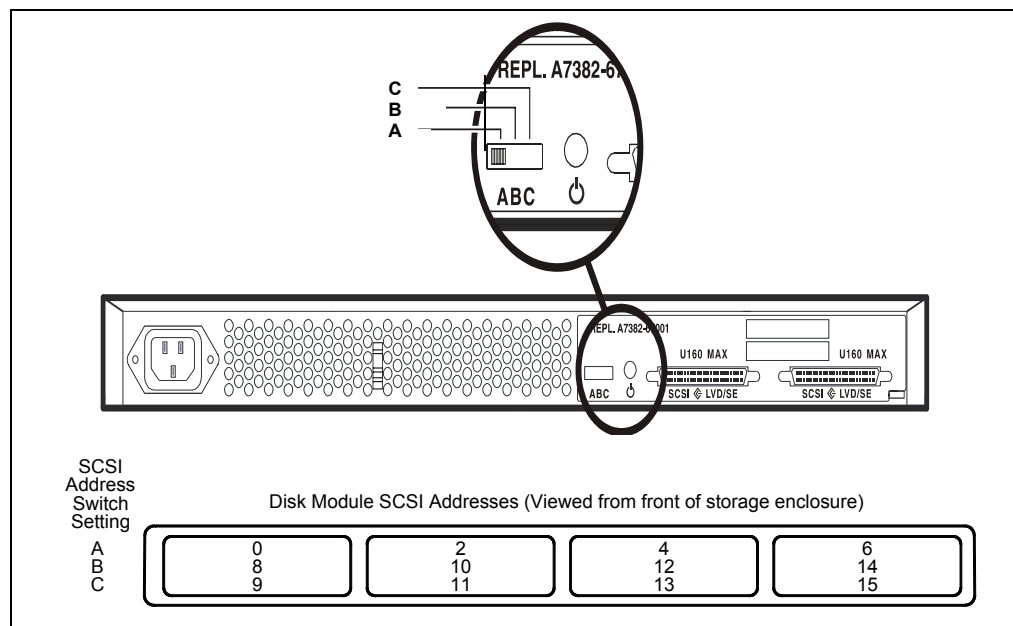

Note The disk system requires a terminator when it is installed at the end of the SCSI bus.

Power Connector

FIGURE 6 AC Power Connector Location

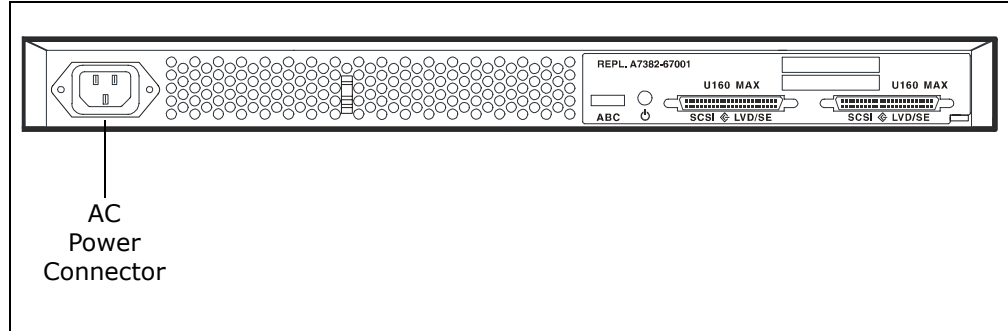

Electrical Requirements

AC Site Requirements

Overcurrent protection devices are required for each cabinet where the disk system is installed. They must be positioned between the power source and the disk system. These protective devices must not trip when exposed to an inrush current of 30 amps lasting 5 ms.

Note These protection devices must meet all applicable electrical safety requirements and be approved for the intended purpose.

TABLE 3 AC Power Requirements

| Electrical Element | Requirements |
|-----------------------|--------------|
| Voltage | 100-240 VAC |
| Frequency | 50-60 Hz |
| Input Current | 1.7-0.7 amp* |
| Maximum Surge Current | 30 amps peak |

* Depending on voltage. Confirm through measurement.

Installing the Disk System

Hardware Requirements

The following hardware is included with the disk system:

One power cord comes with each disk system.

Your host computer must have one of the following:

- An on board LVD SCSI port
- An LVD SCSI host bus adapter board installed in the host system such as A7173A, A6828A, A6829A, A5865A, A7059A, or A7060A.

You can view a complete and current list of supported host bust adapters at http://www.hp.com/products1/serverconnectivity/support_matrices.html.

The following accessory is available for your storage disk system:

- C2364A High Density 68-pin Terminator for LVD or Single-Ended

The DS2120 supports a maximum SCSI speed of U160. Connectivity to U320 initiators is supported if the speed of the U320 initiator is set to limit negotiations to U160 speed. U320 drives do not operate reliably or at acceptable performance levels at U320 speeds and are not supported at those speeds. This is due to limitations within the disk system and not the U320 disk mechanisms. Contact your HP support representative for assistance with the configuration.

Preparing for Installation

Before the disk system is ready for installation, its SCSI IDs must be set and the host system must be prepared to recognize the newly installed disk system. See your operating system administration manual for configuration procedures for the host bus adapter.

Setting the SCSI IDs for the Disk Modules

- 1 Determine which SCSI addresses are not being used on the host system.
Refer to your system administration manual for information on determining which SCSI addresses are available on the host system.
- 2 Locate the SCSI switch on the back of the disk system.

FIGURE 7 SCSI Switch Location

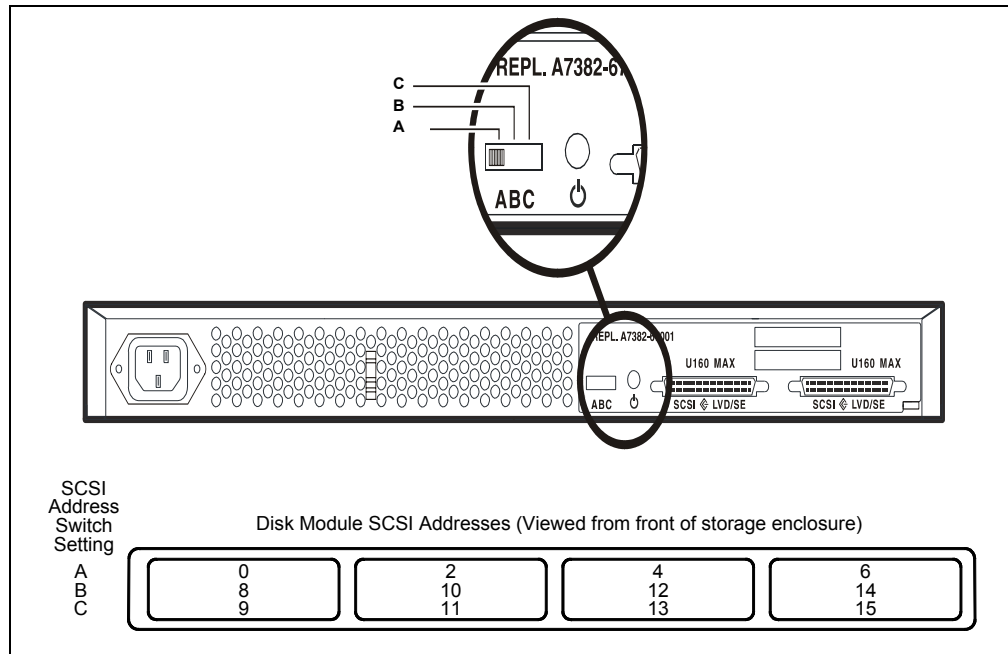

- 3 Set the SCSI IDs.
Verify that the SCSI IDs you have chosen are available. If you are daisy-chaining these disk systems together, each SCSI ID switch must be set for a unique available set of SCSI IDs.

TABLE 4 SCSI Switch Setting Definitions

| SCSI Switch Setting | Disk Slot | | | |
|---------------------|-----------|----|----|----|
| | 1 | 2 | 3 | 4 |
| A | 0 | 2 | 4 | 6 |
| B | 8 | 10 | 12 | 14 |
| C | 9 | 11 | 13 | 15 |

Keep in mind that the host bus adapter should have the highest SCSI address priority. See Table 5 below.

TABLE 5 SCSI Address Priority

| | | | | | | | | | | | | | | | | |
|----------|---------|---|---|---|---|---|---|---|----|----|----|----|----|----|--------|---|
| SCSI ID | 7 | 6 | 5 | 4 | 3 | 2 | 1 | 0 | 15 | 14 | 13 | 12 | 11 | 10 | 9 | 8 |
| Priority | Highest | | | | | | | | | | | | | | Lowest | |

Installing the Disk System

See the installation instructions enclosed with your rackmount kit.

Connect the SCSI Cables

- 1 Make sure that the host system has been powered down.
- 2 Connect one end of an Ultra SCSI cable (included in the shipping box) to the host system. For the SCSI port location on your host system, refer to your host system's documentation.
- 3 Connect the other end of the SCSI cable to one of the LVD/SE ports on the rear of the disk system.

FIGURE 8 SCSI Port Locations

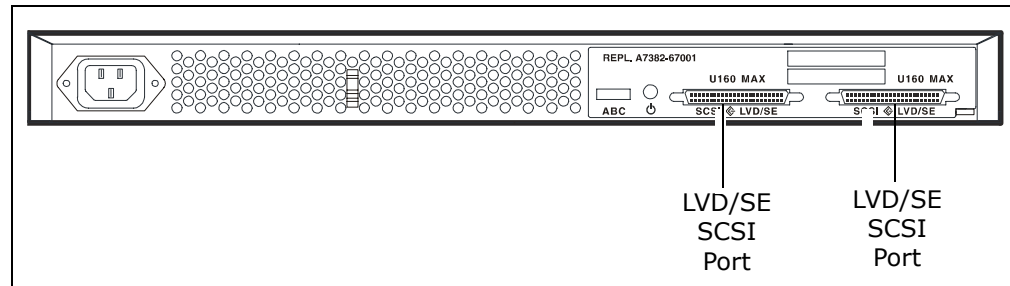

- 4** Determine if this disk system is at the beginning or end of the SCSI bus.
 - If the disk system is at the end of the SCSI bus (you are not going to daisy-chain another device off this one), install the appropriate terminator (part number 5183-2657) on the available SCSI port and go to “Connecting the Power Cable” (see Figure 9 on page 16).
 - If the disk system is at the beginning or middle of the SCSI bus (you are going to daisy-chain another device off this one), consider the following:
 - Due to SCSI ID restrictions, no more than two of these disk systems can be daisy-chained together.
 - For the DS2120, use only 0.5-meter cable between enclosures in daisy-chain configurations. Longer cable lengths between enclosures are not supported.
 - Ensure that the SCSI IDs assigned for the disk drives in the second disk system or other peripheral are not already assigned to another device on the SCSI bus. Refer to “Setting the SCSI IDs for the Disk Modules” (see Figure 7 on page 13 for the SCSI IDs assigned for each SCSI switch setting).
 - If you connected the SCSI cable to the on-board UltraSCSI port on the host system, verify that the SCSI IDs assigned to the disk drives in the second disk system or additional peripherals are not already assigned to any other peripherals installed in the host system.
 - The overall SCSI bus length cannot exceed 9 meters.

The SCSI bus length for the disk system internal cables is 1.1 meters. If another type of peripheral is being connected on this SCSI bus, refer to that peripheral’s documentation for its internal SCSI cable length.
- 5** Connect one end of an Ultra SCSI cable (get it from the shipping box) to the available SCSI port on the rear of the first disk system on the SCSI bus.
- 6** Connect the other end of the Ultra SCSI cable to the unused SCSI connector on the rear of the second disk system on the SCSI bus.
- 7** Repeat Steps 3, 5, and 6 for the last disk system on the SCSI bus if two disk systems are being installed. Keep in mind the maximum bus length (12 meters).
- 8** Install a terminator if the device is the last one on the bus. For supported terminators, see Table 10 on page 33 or Table 12 on page 34.

Note The disk system, when connected at the end of a SCSI bus, requires a terminator. Refer to the documentation that came with your wide SCSI device to determine if it needs a terminator or not. Narrow SCSI devices at the end of a daisy-chain always require a terminator.

Connecting the Power Cable

CAUTION

Ensure that the connection of multiple units to the supply circuit does not overload the supply overcurrent protection or the supply wiring. Refer to the storage electrical ratings when determining the correct branch circuit rating for your installation. See Table 3 on page 11.

FIGURE 9 AC Power Connector Location

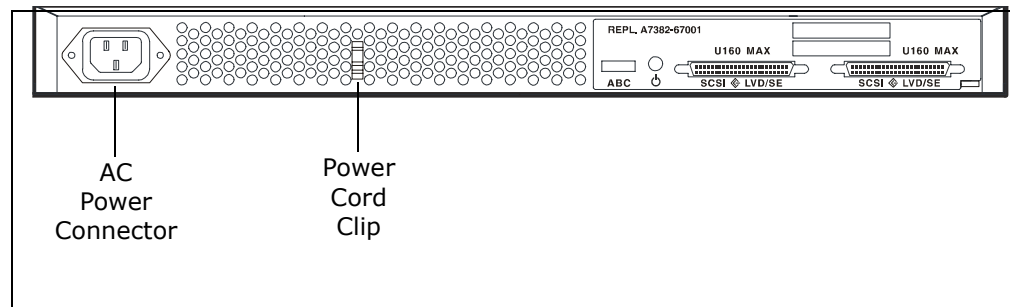

Powering On and Off

Power On the Disk System

- 1 Press the power button and release it. The power button will stay in a depressed position, indicating that the power is on.
See Figure 10 on page 17 for the location of the power button.
- 2 Confirm that the disk system is running properly by checking the system power LED and the disk module LEDs at the front of your disk system. A system reboot may be necessary to assure that the host system recognizes the disk drives within the disk system.

Refer to “Front Panel” on page 3 for explanations of the LED functions and their meanings.

Power Off the Disk System

- 1 Back up all data if the disk system is still operational.
- 2 Ensure that no data on disk modules within the disk system is being accessed.
- 3 Unmount any file systems associated with the disk system that is going to be powered off. Refer to the system administration manual for your host system's operating system for the correct procedure for unmounting a file system or stopping access to the disk modules within the disk system.

Note If your host system's boot or root disk drive resides in the disk system, the host system must be brought down before the power to the disk system can be turned off. See your host system's system administrator's manual for the correct procedures.

- 4 Turn the disk system off by pressing the power button. See Figure 10 (below) for the power button location.
- 5 Confirm that the storage disk system System Power LED is off. See Figure 2 on page 9.
- 6 Disconnect the power cable from the power connector at the rear of the disk system.

FIGURE 10 Power Button Location

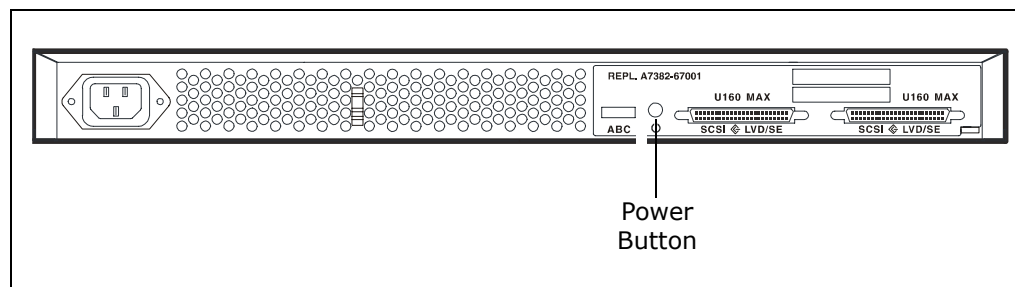

Adding Disk Modules

Disk modules can be added, removed, and replaced while the disk system is running. Because the disk modules can be handled in this way, they are called hot-pluggable.

The SCSI addresses for the disks are set using the addressing switches on the back of the disk system. You can determine the assigned SCSI addresses by looking at the SCSI address switch settings at the rear of the disk system.

If your storage system contains less than 4 disk modules, the remaining empty slots require filler panels. These filler panels ensure that the proper cooling is maintained within the storage system.

The system administration procedure for adding a disk module is operating system specific. You must decide where the disk module is to be installed and install it. Once the disk module is installed, the operating system must be configured to recognize it.

Add a Disk Module

- 1** Select an available slot for the new disk module. Note the slot chosen for application configuration.
- 2** Remove the disk module filler panel. Store the filler panel for future use.
- 3** Hold the locking handle open on the disk drive. Push the locking lever to the left to release the latch.
- 4** Slide the disk into the appropriate slot until it engages with the backplane.
- 5** Press on the locking handle until it locks. You will hear an audible click when the locking mechanism is fully engaged.

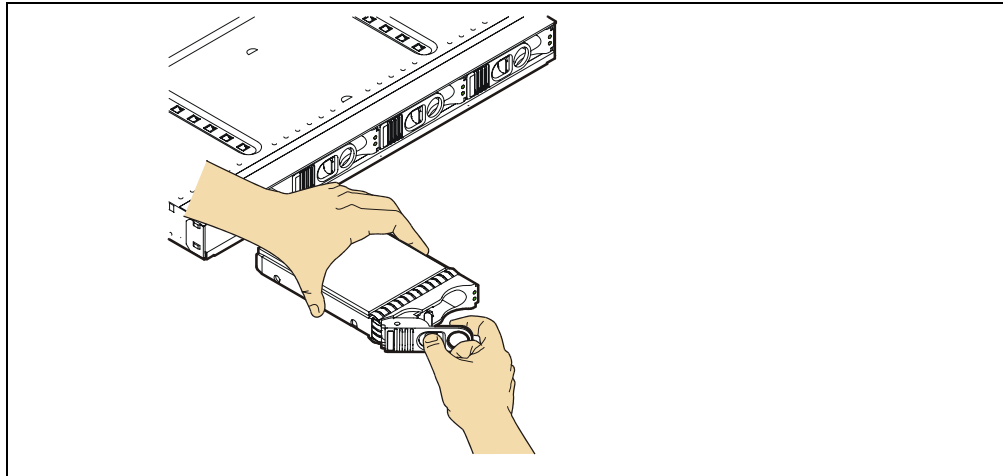
FIGURE 11 Installing a Disk Module

Configure the new Disk Module

Configure a new disk module within your application.

CAUTION

These procedures should be performed only by qualified system administrator. Performing hot-plug operations on an active disk drive can result in data loss or corruption.

Remove and Replace A Disk Module

Remove a Disk Module

CAUTION

If the disk system is running and a disk module slot does not contain a disk drive or filler panel, the disk system will not cool properly and may overheat. If you are not replacing the disk module immediately, a filler panel must be installed to maintain proper cooling.

Ensure that you have a replacement disk or filler panel before removing the disk module from the disk system unless you are returning a defective disk system.

- 1 Ensure there is no activity on the drives.

If the Disk Drive LED for that disk module is flashing green, the disk drive is active. When the Disk Drive LED off, the disk module is either idle or completely off (see Table 1 on page 8). In this state, it is safe to remove the disk module.

- 2 Prepare the software environment to remove the drive.

See your operating system documentation for instructions and procedures required to remove a disk module. It may be necessary to unmount file systems associated with the disk drives installed in the disk system.

- 3 Unlatch the disk module handle and remove the disk module.

Squeeze the latch to unlock the disk module. Put a finger behind the latch and pull the disk module out until it disengages from the backplane. Leave it in its slot for two to three minutes to allow the disk drive to spin down before removing the disk module from the enclosure.

If you are going to replace the disk module immediately, refer to “Replace a Disk Module” below.

If you are not going to replace the disk module immediately insert a filler panel into the open slot to assure the required cooling.

Replace a Disk Module

- 1 Refer to your operating system documentation for requirements and procedures for replacing disk modules.
- 2 Align the replacement disk module with the disk module slot.
- 3 Slide the disk module into the slot until it engages with the backplane.
- 4 Press on the locking handle until it locks. You will hear an audible click when the locking mechanism is fully engaged.

Remove the Disk System

CAUTION

Some data paths may be slot-dependent. Be sure to note the slot from which the disk module is removed so it can be installed in the same slot in the replacement disk system.

Reverse the installation instructions enclosed with the rackmount kit for your cabinet:

- A7552A - Hewlett-Packard Rack Systems/E for Enterprise Systems
- A5680A - all other Hewlett-Packard rack systems for Enterprise Systems purchased before November 1998.

If your disk system is a factory-integrated unit, see the figure below for removal instructions.

FIGURE 12 Removing the Disk System

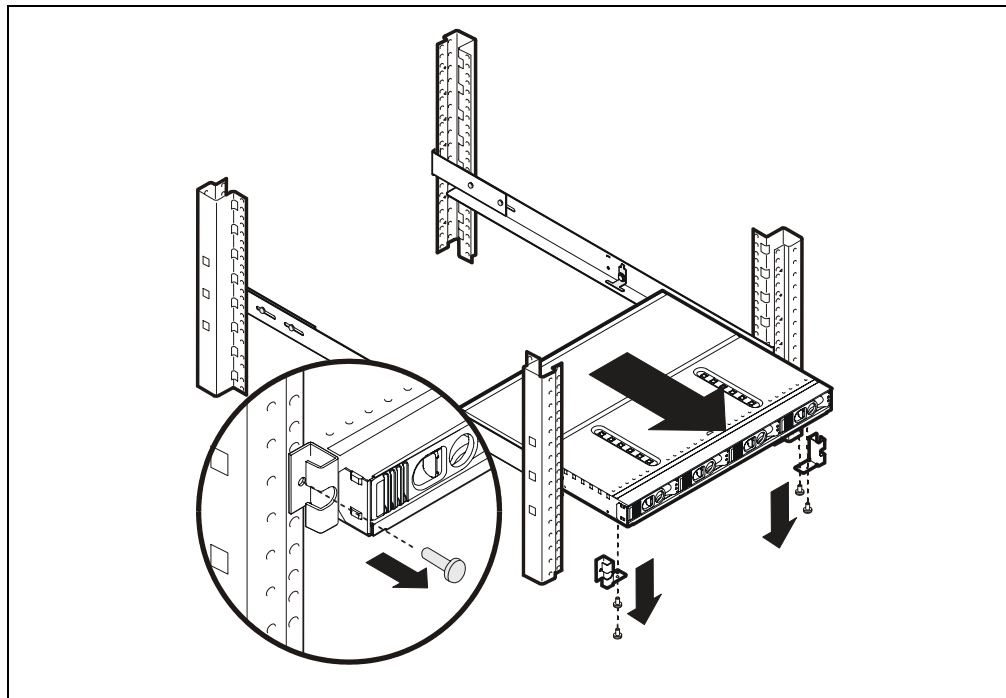

If you are exchanging a desktop disk system, be sure to remove and store the plastic Desktop Disk System Cover for use on the replacement disk system.

Setting Up the Hardware Event Monitor (HP-UX Only)

Hardware event monitors run on HP-UX hosts, versions 10.20 and later. The Disk Monitor (disk_em) monitors all disks bound to sdisk drivers. Consequently, if the Disk Monitor is active on your host, it is already set up to monitor the disks of a new disk system. If you need to install or activate the Disk Monitor, refer to the *EMS Hardware Monitors User's Guide* in the latest IPR Support Media or on the Web (<http://www.docs.hp.com/hpux/diag/>).

Note This Disk Monitor should not be confused with the EMS disk monitor that is used to monitor LVM resources.

The way you configure the monitor determines, among other things, where event messages will be sent and what level of severity will be reported.

Configuration Overview

The following steps will help you identify and resolve disk system failures:

- 1** Gather information from all sources:
 - Hardware event notifications (page 25)
 - Disk system LED status (page 25)
 - Online information tools (page 26)
- 2** Isolate the cause of the problem (Table 7 on page 30).
- 3** Correct the problem. (See page 19 for disk module removal and replacement.)
- 4** Verify operational status with *ioscan* or other host utilities.

Event Notification (HP-UX Only)

The Disk Monitor, an EMS hardware event monitor, reports changes in disk status. Depending on how the monitor is set up, it sends messages to the console, an e-mail address, a log file, or a third-party application. These messages give early notice of a disk problem. Events include media errors, failed read and write attempts, invalid commands, changed operating parameters, failed diagnostics, and many others.

Event severity ranges from critical to informational:

| | |
|--------------------|---|
| Critical | An event that causes data loss, host system downtime, or other loss of service. Host system operation will be affected if the disk system continues to be used without correction. Immediate action is required. For example, read data could not be recovered. |
| Serious | An event that may cause data loss, host system downtime, or other loss of service if left uncorrected. Host system and hardware operation may be adversely affected. The problem needs repair as soon as possible. For example, the request queue is full. |
| Warning | An event that could escalate to a serious condition if not corrected. Host system operation should not be affected and normal use of the disk system can continue. Repair is needed but at a convenient time. For example, the bus failed to reset. |
| Information | An event that is expected as part of the normal operation of the hardware. No action is required. For example, write protection was switched on or off. |

Event messages (see Figure 13) contain the following types of information:

- **Message Data** – Date and time the message was sent, the source and destination of the message, and the severity level.
- **Event Data** – Date and time of the event, the host, event ID, name of the monitor, event number, event class, severity level, hardware path, associated OS error log entry ID.
- **Error Description** – Narrative information indicating the component that experienced the event and the nature of the event.
- **Probable Cause/Recommended Action** – The cause of the event and suggested steps toward a solution. This information should be the first step in troubleshooting.

FIGURE 13 Sample Hardware Event Notification

```
Notification Time: Wed Feb 3 11:27:15 1999
yourserver sent Event Monitor notification information:
/storage/events/disks/default/10_4_4_0.0 is >=1.
Its current value is CRITICAL(5)
Event data from monitor:
Event Time: Wed Feb 3 11:27:15 1999
Hostname: yourserver.rose.hp.com      IP Address : 15.43.213.13
Event ID: 0x0036b8a313000000002      Monitor    : disk_em
Event # : 100037                      Event Class: I/O
Severity : CRITICAL

Disk at hardware path 10/4/4/0.0 : Media failure
Associated OS error log entry id(s) : 00000000000000000000

Description of Error:

    The device was unsuccessful in reading data for the current I/
    O request due to an error on the medium. The data could not be
    recovered. The request was likely processed in a way which
    could cause damage to or loss of data.

Probable Cause / Recommended Action:

    The medium in the device is flawed. If the medium is removable,
    replace the medium with a fresh one. Alternatively, if the
    medium is not removable, the device has experienced a hardware
    failure. Repair or replace the device, as necessary.
```

Status LEDs

LEDs indicate the status of the disk system itself and each of the disk modules. A green system LED is visible on the front of the disk system. It shows that a fault has occurred or that power is on. Disk activity LEDs are on the front of the disk modules (see Figure 14 and Table 6 below).

FIGURE 14 LED Status Indicators

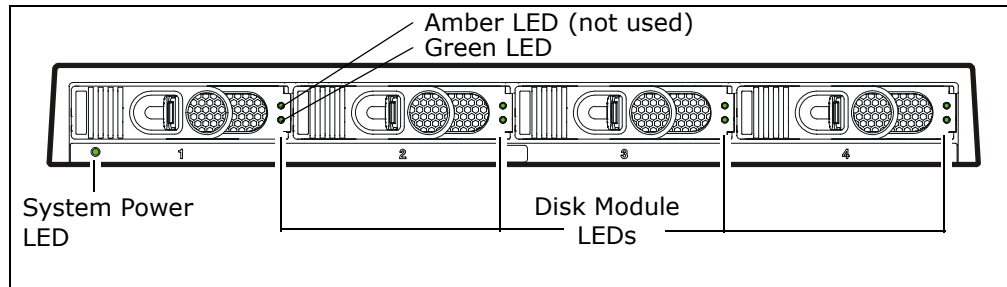

TABLE 6 LED Status Indicators

| LED | State | Indication |
|--------------|----------|---|
| System Power | Green | Power is on |
| | Blinking | Malfunction - either a fan is not operating properly or internal voltage is too low. |
| | OFF | Power is off |
| Disk Module | Green | Installed and spinning up. If the LED is still on 3 minutes after term power is engaged and there is no I/O activity occurring, the disk may be faulty. |
| | Flashing | I/O activity on the disk. The LED flashes at variable speeds, depending on the I/O activity. The LED may appear to be on solid during periods of high I/O activity. |
| | OFF | Not installed, not operating, or no I/O activity |

View Disk Status

HP-UX and MPE/iX utilities provide descriptive and diagnostic information about disks, including disk type, firmware revision, and errors. On HP-UX and MPE/iX 6.5 or later, the disk utility is Support Tools Manager (STM). For all other operating systems, consult the appropriate system administration manual for disk module status checking procedures.

STM Disk Information: HP-UX

STM displays the last-generated Information Log for a selected disk. Start STM and run the Information tool as follows.

- 1** Log on the system.
- 2** At the system prompt, type **xstm&**. STM starts and displays a graphic of the devices on the system.
- 3** Select the desired disk.
- 4** Select **Information** from the Tools menu.
- 5** To generate a current log, select **Run**. The log will be displayed as soon as it is generated
- 6** To view a log without updating the contents, select **Information Log**.
- 7** Select **Done** when you have finished viewing the information.
- 8** To quit STM, type **exit**.

Figure 15 shows a sample Information Log.

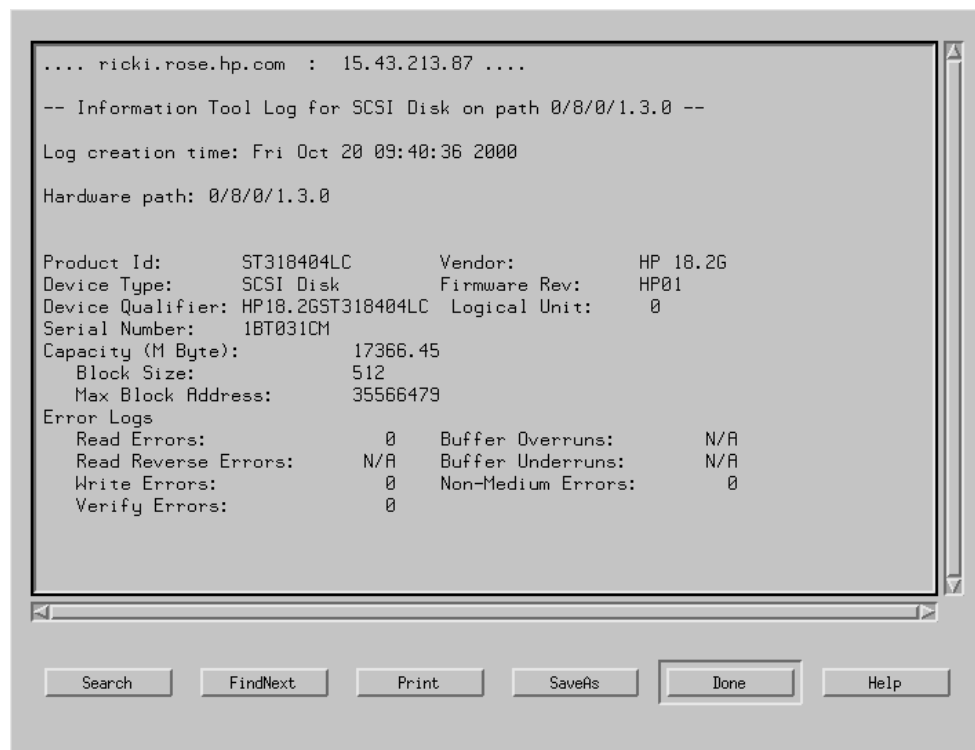
FIGURE 15 Sample STM Information Log (HP-UX)

STM Disk Information: MPE/iX 6.5 or Later

STM displays the last-generated Information Log for a selected disk. Start STM and run the Information tool as follows.

- 1 Log on the system.
- 2 At the system prompt (:), type **vsclose** <physical volume number>. This removes the disk from use.
- 3 At the system prompt (:), type **cstm**. STM starts.
- 4 At the cstm prompt, type **map**. STM displays a list of all the disks installed on the system.
- 5 Select the desired disk by typing **select device** <number>; for example, **select device 15**.
- 6 Type **information**. STM updates the system map.
- 7 To display the information log, type **info log**. A sample information log is shown in Figure 16.

FIGURE 16 Sample STM Expert Tool Disk Error Log (MPE/iX 6.5 or Later)

```
Write Error Statistics

Errors Corrected Without Delay:  N/A
Errors Corrected With Delay:    0
Total Retries:                  0
Total Errors Corrected:         0
Correction Algorithm Executions: 0
Total Bytes Processed:          6.3253e+10
Total Uncorrected Errors:       0

Read Error Statistics

Errors Corrected Without Delay:  23781
Errors Corrected With Delay:    0
Total Retries:                  0
Total Errors Corrected:         23781
Correction Algorithm Executions: 23781
Total Bytes Processed:          9.6191e+10
Total Uncorrected Errors:       0

Read Reverse Error Statistics

Errors Corrected Without Delay:  N/A
Errors Corrected With Delay:    N/A
Total Retries:                  N/A
Total Errors Corrected:         N/A
Correction Algorithm Executions: N/A
Total Bytes Processed:          N/A
Total Uncorrected Errors:       N/A

Verify Error Statistics

Errors Corrected Without Delay:  0
Errors Corrected With Delay:    0
Total Retries:                  0
Total Errors Corrected:         0
Correction Algorithm Executions: 0
Total Bytes Processed:          36864
Total Uncorrected Errors:       0

Non-Medium Error Counts:        0
```

Isolating Faults

Table 7 lists the probable causes and solutions for problems you may detect on the disk system. When more than one problem describes your situation, investigate the first solution that applies. The table lists the most basic problems first and excludes them from subsequent problem descriptions.

Erratic LED behavior on the disk system could be observed in the following situations:

- When a server that is connected to a Disk System 2120 is powered down or loses power (and the disk system remains powered on)
- When the disk system is powered up when connected to a downed server
- When an unconnected disk system is powered up

An example of this LED behavior is the LEDs staying lit solidly. This condition is caused by the disk system being deprived of term power when the server loses power or is powered down. The disk system does not provide its own term power. It relies on the host bus adapter to which it is connected for term power.

TABLE 7 Troubleshooting Table

| Problem Description | LED State | Probable Cause | Solution |
|---|------------------------------------|--|---|
| Disk system fails to power on when installed | System power LED is off | Power cord is not plugged in. | Plug in the power cord. |
| | | The power button is not pressed. | Press the power button. |
| | | AC breaker is tripped or AC power source has failed. | Confirm AC power availability. |
| | | The PDU/PDRU is defective. | Replace the PDU/PDRU. |
| | Enclosure chassis is faulty. | Replace the enclosure chassis. | |
| | System power LED is blinking | Power supply is defective. | Replace the enclosure chassis. |
| Cooling fans are not spinning at the correct speed. | | Replace the enclosure chassis. | |
| Operating system reports errors on a device | Disk module LED is on solid or off | Use diagnostic utilities to determine disk status. | Depending on the results, monitor or replace disk module. |

| Problem Description | LED State | Probable Cause | Solution |
|--|------------------------------------|---|---|
| <i>ioscan</i> (HP-UX) lists disk as NO_HW, or Mapper or <i>dstat all</i> (MPE/iX) lists no device type | Disk module LED is on solid or off | Disk module is faulty. | Replace the disk module. |
| | | Enclosure is faulty. | Replace the enclosure chassis. |
| | | If the all disks on the bus have this problem, the cable is faulty. | Replace the cable. |
| Unable to configure device for use by operating system | Disk module LED is on solid or off | Disk module possibly not correctly seated. | Remove and reinstall the disk module. |
| | | If troubleshooting an existing installation, run diagnostics to determine drive status. | If the problem cannot be resolved, replace the disk module. |

Reference Information

Product Numbers and Options

TABLE 8 Product Numbers

Disk System 2120

| Product Number | UPC Code | Description |
|----------------|-----------------|--|
| A7382A | | Field-racked disk system with at least one drive |
| A7382AD | | Desktop disk system with at least one drive |
| A7382AE | 8 29160-27519 2 | Field-racked disk system, empty enclosure only |
| A7382AZ | 8 29160-27520 8 | Factory-racked disk system with at least one drive |
| A7382ED | 8 29160-27521 5 | Desktop disk system, empty enclosure only |

When ordering disk modules for a product, specify Option OD1 to install the module in the product before it ships from the factory. For example, to order a desktop Disk System 2120 with one 146-GB, 10,000 rpm disk module, request the following:

| Product Number | Qty. | Description |
|----------------|------|--|
| A7382AD | 1 | Desktop Disk System 2120 |
| A7530A | 1 | 146-GB 10,000 rpm HDD U320 disk module |
| A7530A (OD1) | 1 | Factory integration of the disk module |

Upgrade Disk Products Available

TABLE 9 Available Upgrade Disk Modules

| Product Number | UPC Code | Description ¹ |
|----------------|-----------------|--|
| A7527A | 8 29160-54330 7 | 36-GB 15,000 rpm HDD U320 disk module |
| A7528A | 8 29160-54331 4 | 73-GB 10,000 rpm HDD U320 disk module |
| A7529A | 8 29160-54332 1 | 73-GB 15,000 rpm HDD U320 disk module |
| A7530A | 8 29160-54333 8 | 146-GB 10,000 rpm HDD U320 disk module |

¹ The U320 drives are supported at 160 MB/s speeds only. U320 drives do not operate reliably or at acceptable performance levels at 320 MB/s speeds and are not supported at those speeds. This is due to limitations within the disk system and not the disk mechanisms.

TABLE 10 Upgrade Products for Hewlett-Packard Systems

| Product Number | Description ¹ |
|----------------|---|
| A4999A | Single Port Ultra2 SCSI Host Bus Adapter for Hewlett-Packard Workstations |
| A7531A | Deskside Pedestal Kit |
| A7552A | Rail kit for the Rittal Style Rack Systems and HP Rack Systems/E |
| A5856A | Internal Disk Array Controller for HP-UX Systems |
| A7382A | HP StorageWorks Disk System 2120 |
| C2364A | LVD/SE SCSI Terminator (HDTS68) |

¹ A complete and current list of supported host bus adapters is available at http://www.hp.com/products1/serverconnectivity/support_matrices.html

TABLE 11 Replaceable Parts

| Product Number | Description | Replaceable Part Numbers | CRU² | FRU³ |
|-----------------------|--------------------------------------|---------------------------------|------------------------|------------------------|
| A7372A | DS2120 Base Disk System Assembly | A7382-69001 | Yes | Yes |
| A6198A | Disk Filler Panel | A6198-67002 | Yes | Yes |
| A7527A ¹ | 36-GB 15,000 rpm HDD U320 disk mod. | A9896-69001 | Yes | Yes |
| A7528A ¹ | 73-GB 10,000 rpm HDD U320 disk mod. | A9897-69001 | Yes | Yes |
| A7529A ¹ | 73-GB 15,000 rpm HDD U320 disk mod. | A7529-69001 | Yes | Yes |
| A7530A ¹ | 146-GB 10,000 rpm HDD U320 disk mod. | A9898-69002 | Yes | Yes |
| | Desktop Disk System Cover | 5065-5217 | No | Yes |
| | Desktop Disk System Feet | 0403-0285 | No | Yes |

¹ The U320 drives are supported at 160 MB/s speeds only. U320 drives do not operate reliably 320 MB/s speeds and are not supported at those speeds. This is due to limitations within the disk system and not the disk mechanisms.

² Customer Replaceable Unit

³ Field Replaceable Unit

TABLE 12 Supported HP Cables and Terminators

| Order Number | Description | Part Number |
|---------------------|---|--------------------|
| C2978B | 0.5-meter HDT S68 SCSI multimode cable | 5183-2670 |
| C2911C | 1.0-meter HDT S68 SCSI multimode cable | 5183-2671 |
| C2979B | 1.5-meter HDT S68 SCSI multimode cable | 5183-2672 |
| C2924C | 2.5-meter HDT S68 SCSI multimode cable | 5183-2673 |
| C7521A | 5.0-meter HDT S68 SCSI multimode cable | 5183-2678 |
| C2361B | 1.0-meter VHDT S68/HDT S68 SCSI multimode cable | 5183-2674 |
| C2362B | 2.5-meter VHDT S68/HDT S68 SCSI multimode cable | 5183-2675 |
| C2365B | 5.0-meter VHDT S68/HDT S68 SCSI multimode cable | 5183-2676 |
| C2364A | SCSI Terminator LVD/SE HDTS68 | 5183-2657 |

Specifications

TABLE 13 Physical Dimensions

| Measure | Metric | English |
|-----------------------------|----------|----------|
| Width | 44.85 cm | 17.65 in |
| Depth | 37.60 cm | 14.8 in |
| Height | 4.32 cm | 1.7 in |
| Weight without disk modules | 4.99 kg | 11.0 lbs |
| Weight fully loaded | 8.21 kg | 18.1 lbs |

Electrical Specifications

TABLE 14 AC Power Requirements

| Electrical Element | Requirement |
|-------------------------|-------------------|
| Product Voltage Range | 100 - 240 VAC RMS |
| Product Frequency Range | 50 - 60 Hz |

TABLE 15 Environmental Specifications

| Climate Control | | |
|--|-----------|------------------------------------|
| Disk System 2120 Temperature (dry bulb) | Operating | 0°C - +40°C |
| | Storage | -40°C - +70°C |
| Relative Humidity (non-condensing) | Operating | 5% - 95% Relative Humidity at 40°C |
| | Storage | 90% Relative Humidity at 65°C |
| Altitude (based on disks) | Operating | -1000 ft to +10,000 ft (3048 M) |
| | Storage | 40,000 ft (12,092 M) |
| Heat Dissipation (maximum) | Operating | < 100 watts |

Operating Temperatures

If the storage system is installed in a multi-unit rack assembly, the operating ambient temperature of the rack environment may exceed room ambient temperature. For the Disk System 2120 the rack environment ambient temperature cannot exceed 40° Celsius (104° Fahrenheit).

If your storage system contains less than 4 disk modules, the remaining empty slots require filler panels. These filler panels (part number A6198-60002) ensure that the proper cooling is maintained within the storage system.

Regulatory Statements

Safety Certifications

UL listed, UL 1950:1995 – 3rd Edition

CSA certified, C22.2 No. 950:1995

TUV certified with GS mark, EN 60950:1992 + A1:1993, A2:1993, A3:1995, A4:1997, A11:1997

EMC Compliance

Australia: AS/NZS 3548, Class A

Canada: ICES-003, Class A

China: GB9254-88

European Union: EN55022 Class A, EN55024

Japan: VCCI Class A

Taiwan: CNS 13438, Class A

US: 47 CFR Parts 2 & 15, Class A

A. FCC Notice for United States

The Federal Communications Commission (in 47 CFR 15.105) has specified that the following notice be brought to the attention of the users of this product.

This equipment has been tested and found to comply with the limits for a Class A digital device, pursuant to Part 15 of the FCC Rules. These limits are designed to provide reasonable protection against harmful interference when the equipment is operated in a commercial environment. This equipment generates, uses, and can radiate radio frequency energy and, if not installed and used in accordance with the instruction manual, may cause harmful interference to radio communications.

Hewlett-Packard's certification tests were conducted with a Hewlett-Packard supported computer system and Hewlett-Packard shielded cables, such as those you received with your storage product. Changes or modifications not expressly approved by Hewlett-Packard could void the user's authority to operate the equipment. Cables used with this device must be properly shielded to comply with the requirements of the FCC.

B. Canadian Notice (Avis Canadien)

This Class A digital apparatus meets all requirements of the Canadian Interference-Causing Equipment Regulations.

Cet appareil numérique de la classe A respecte toutes les exigences du Règlement sur le matériel brouilleur du Canada.

C. Notice for European Union

This is a Class A product. In a domestic environment this product may cause radio interference, in which case the user may be required to take adequate measures.

D. Notice for France

DECLARATION D'INSTALLATION ET DE MISE EN EXPLOITATION d'un matériel de traitement de l'information (ATI), classé A en fonction des niveaux de perturbations radioélectriques émis, définis dans la norme européenne EN 55022 concernant la Compatibilité Electromagnétique.

E. Notice for Japan

この装置は、情報処理装置等電波障害自主規制協議会（VCCI）の基準に基づくクラスA情報技術装置です。この装置を家庭環境で使用すると電波妨害を引き起こすことがあります。この場合には使用者が適切な対策を講ずるよう要求されることがあります。

F. Harmonics Conformance (Japan)

高調波ガイドライン適合品

G. Japanese Power Cord Statement

製品には、同梱された電源コードをお使い下さい。
同梱された電源コードは、他の製品では使用出来ません。

translation

Please use the attached power cord.

The attached power cord is not allowed to use with other product.

H. BSMI

警告使用者：這是甲類的資訊產品，在居住的環境中使用時，可能會造成射頻干擾，在這種情況下，使用者會被要求採取某些適當的對策。

I. Notice for Germany

Schalldruckpegel $L_p = 55.0$ dB(A)

Am Arbeitsplatz (operator position)

Normaler Betrieb (normal operation)

Nach ISO 7779:1999 (Typprüfung)

Product Web Site

For the most current information about the HP StorageWorks Disk System 2120, visit the support Web site located at <http://www.hp.com/support>.

Related Documents

The following resources contain information on using the system software interfaces to the HP StorageWorks Disk System 2120:

- *Online Diagnostics (for HP 9000): Support Tools Manager Overview*, available at <http://docs.hp.com/hpux/diag/>
- HP-UX documentation, available at <http://docs.hp.com>